



ENGINEER FIELD MANUAL

VOLUME 15

## RIGGING

### WARNING

ALTHOUGH NOT CLASSIFIED, THIS PUBLICATION, OR ANY PART OF IT, MAY BE EXEMPTED FROM DISCLOSURE TO THE PUBLIC UNDER THE ACCESS TO INFORMATION ACT. ALL ELEMENTS OF INFORMATION CONTAINED HEREIN MUST BE CLOSELY SCRUTINIZED TO ASCERTAIN WHETHER OR NOT THE PUBLICATION, OR ANY PART OF IT, MAY BE RELEASED.

Issued on Authority of the Chief of the Defence Staff

Canada

## **FOREWORD**

1. B-GL-320-015/FP-000, Engineer Field Manual, Volume 15, Rigging, is issued on the authority of the Chief of the Defence Staff.
2. This publication is effective upon receipt.
3. Suggestions for amendments shall be forwarded through normal channels to Chief of Land Staff, Attention: Director of Army Doctrine 8 (Protection).

## TABLE OF CONTENTS

### CHAPTER 1 - INTRODUCTION

GENERAL .....	1
AIM .....	1
SCOPE .....	1
REFERENCES .....	2
DIMENSIONS .....	2
<b>ANNEX A - IMPERIAL-METRIC CONVERSION TABLES .....</b>	<b>3</b>

### CHAPTER 2 - CORDAGE

#### SECTION 1 - TYPES OF CORDAGE

GENERAL .....	8
IDENTIFICATION OF CORDAGE .....	8
VEGETABLE FIBRES .....	9
SYNTHETIC FIBRES .....	9

#### SECTION 2 - CARE OF CORDAGE

GENERAL .....	11
WHIPPING OF CORDAGE .....	12
PARCELLING CORDAGE .....	12
INSPECTION OF CORDAGE .....	13

#### SECTION 3 - KNOTS, BENDS AND HITCHES

GENERAL .....	14
SEIZING AND FRAPPING .....	15
STOPPER KNOTS FOR CORDAGE .....	15
KNOTS JOINING TWO LENGTHS OF CORDAGE .....	16
KNOTS SECURING CORDAGE TO A SPAR, HOOK OR RING..	17
KNOTS FORMING LOOPS IN CORDAGE .....	20
KNOTS TO SHORTEN OR TIGHTEN CORDAGE .....	22

#### SECTION 4 - SPLICING

GENERAL .....	23
SHORT SPLICING .....	23
LONG SPLICING .....	25
EYE SPLICES .....	26
BACK SPLICING .....	27

#### SECTION 5 - LASHINGS

GENERAL .....	28
STRENGTH AND SIZE OF LASHING .....	28
TYPES OF LASHING .....	29

**SECTION 6 - CORDAGE STRENGTH**

CORDAGE SIZE AND WEIGHT ..... 31  
SAFE WORKING LOAD ..... 32  
WORKING WITH CORDAGE BY HAND ..... 36  
**ANNEX A - COMPARATIVE QUALITIES OF NATURAL AND  
SYNTHETIC CORDAGES ..... 37**

**CHAPTER 3 - STEEL WIRE ROPE**

**SECTION 1 - INTRODUCTION**

GENERAL ..... 39  
CONSTRUCTION ..... 39  
LAY ..... 40  
CLASSIFICATION ..... 41

**SECTION 2 - CARE AND MAINTENANCE OF SWR**

COILING STEEL WIRE ROPE ..... 43  
CARE OF STEEL WIRE ROPE ..... 44  
INSPECTION ..... 46  
COMMON CAUSES OF SWR FAILURES ..... 47

**SECTION 3 - FASTENINGS AND FITTINGS**

GENERAL ..... 48  
TYPES OF KNOTS ..... 48  
CLAMPS ..... 48  
THIMBLES ..... 50  
SHACKLES ..... 51  
HOOKS ..... 51

**SECTION 4 - SAFE WORKING LOAD OF SWR**

SWR SIZE, WEIGHT AND STRENGTH ..... 53  
SWR SAFE WORKING LOAD ..... 55

**ANNEX A - SAFE WORKING LOAD OF HOOKS ..... 57**

**ANNEX B - SWR CHARACTERISTICS AND APPLICATIONS ..60**

**CHAPTER 4 - CHAINS**

GENERAL ..... 62  
TYPES OF CHAINS ..... 62  
CHAIN GRADES ..... 63  
STRENGTH ..... 63  
INSPECTION ..... 64  
CARE AND USE ..... 67

**CHAPTER 5 - SLINGS**

GENERAL.....	69
SAFETY .....	69
SLING CONFIGURATIONS .....	70
SLING ANGLES .....	73
SAFE WORKING LOADS.....	74
<b>ANNEX A - SAFE WORKING LOAD OF SLINGS.....</b>	<b>75</b>

**CHAPTER 6 - ANCHORAGES**

GENERAL.....	81
TYPES .....	81
EXISTING NATURAL OR STRUCTURAL HOLDFASTS .....	81
WOODEN PICKET HOLDFASTS .....	83
STEEL PICKET HOLDFASTS.....	83
SURFACE BAULK ANCHORAGES .....	85
BURIED BAULK ANCHORAGES .....	86
CONSTRUCTION.....	90
STRAIGHT PULL ROCK ANCHORAGE .....	90
ELEVATED CABLE ANCHORAGE SYSTEM .....	91
TOWERS .....	92
CABLE .....	93
BRIDGE / RAFT TYPES .....	94
ANCHORS.....	95
<b>ANNEX A - DESIGN CALCULATIONS FOR BURIED     (DEADMAN) ANCHORAGES.....</b>	<b>98</b>
<b>ANNEX B - DESIGN CALCULATIONS FOR AN ELEVATED     CABLE ANCHORAGE.....</b>	<b>101</b>

**CHAPTER 7 - BLOCKS AND TACKLES****SECTION 1 - TACKLES**

GENERAL.....	104
TERMINOLOGY .....	104
BLOCKS.....	106
CARE OF TACKLES .....	106
SAFETY PRECAUTIONS .....	107

PULL APPLIED BY PERSONNEL ..... 107

**SECTION 2 - MAKING TACKLES**

SELECTING THE BLOCK ..... 108

REEVING CORDAGE TACKLES ..... 108

STEEL WIRE ROPE TACKLES..... 109

ANTI-TWISTERS ..... 109

BLOCK LASHING ..... 110

MOUSING ..... 111

**SECTION 3 - MECHANICAL ADVANTAGE OF TACKLES**

GENERAL ..... 112

THEORETICAL GAIN..... 112

COEFFICIENT OF FRICTION ..... 113

CALCULATIONS ..... 113

LIMITING FACTORS..... 114

**ANNEX A - EXAMPLE TACKLE DESIGN..... 116**

**CHAPTER 8 - FIELD MACHINES**

**SECTION 1 - STANDING DERRICKS**

DESCRIPTION ..... 119

GUYS ..... 119

CONSTRUCTING A DERRICK..... 120

**SECTION 2 - SHEERS**

DESCRIPTION ..... 122

CONSTRUCTION SEQUENCE ..... 122

TENSION..... 123

GUYS ..... 124

SETTING UP..... 125

**SECTION 3 - GYNS**

DESCRIPTION ..... 126

CONSTRUCTION SEQUENCE ..... 126

WORKING WITH GYNS ..... 127

DESIGN ..... 127

**CHAPTER 9 - ELEVATED CABLES**

GENERAL ..... 128

DESIGN ..... 128

CONSTRUCTION ..... 129

**ANNEX A - DESIGN PROFORMA FOR FIELD MACHINES .. 132**

## LIST OF FIGURES

Fig 1A-1	Linear measures .....	3
Fig 1A-2	Surface measures .....	3
Fig 1A-3	Volume capacity .....	4
Fig 1A-4	Weight measure .....	4
Fig 1A-5	Force .....	5
Fig 1A-6	Mass per unit length.....	5
Fig 1A-7	Mass per unit area.....	5
Fig 1A-8	Mass per unit volume.....	5
Fig 1A-9	Stress and pressure.....	6
Fig 1A-10	Meaning of metric prefixes .....	6
Fig 1A-11	Conversion tables.....	7
Fig 2-1-1	Hawser Lay cordage.....	8
Fig 2-1-2	Fibre identification colour coding table .....	9
Fig 2-2-1	Coiling and uncoiling cordage.....	12
Fig 2-2-2	A method of whipping.....	13
Fig 2-2-3	An alternate method of whipping .....	13
Fig 2-3-1	Terminology when using cordage .....	14
Fig 2-3-2	Seizing and frapping.....	15
Fig 2-3-3	Thumb knot (top)and figure of eight knot (bottom) .....	15
Fig 2-3-4	Reef knots.....	16
Fig 2-3-5	Granny and thief knots .....	16
Fig 2-3-6	Double sheet bends.....	16
Fig 2-3-7	Hawser bend.....	17
Fig 2-3-8	Carrick bend .....	17
Fig 2-3-9	Timber hitch .....	17
Fig 2-3-10	Clove hitch .....	18
Fig 2-3-11	Round turn and two half hitches .....	18
Fig 2-3-12	Fisherman's bend .....	18
Fig 2-3-13	Draw hitch .....	19
Fig 2-3-14	Rolling hitch.....	19
Fig 2-3-15	Stopper hitch .....	19
Fig 2-3-16	Lever hitch .....	19
Fig 2-3-17	Bowline .....	20
Fig 2-3-18	Running bowline .....	20
Fig 2-3-19	Double bowline .....	20
Fig 2-3-20	Bowline on a bight .....	21
Fig 2-3-21	Catspaw .....	21
Fig 2-3-22	Single Blackwall hitch.....	21
Fig 2-3-23	Double Blackwall hitch.....	21

## Rigging

Fig 2-3-24	Harness hitch .....	22
Fig 2-3-25	Sheep shank .....	22
Fig 2-3-26	Baker bowline.....	22
Fig 2-4-1	Short splice .....	24
Fig 2-4-2	Long splice .....	25
Fig 2-4-3	Eye splice .....	26
Fig 2-4-4	Back splice .....	27
Fig 2-5-1	Square lashing .....	29
Fig 2-5-2	Diagonal lashing .....	29
Fig 2-5-3	Pole lashing .....	30
Fig 2-6-1	Elasticity of cordage .....	31
Fig 2-6-2	Weight of natural and synthetic cordage.....	32
Fig 2-6-3	Minimum breaking strength of natural and synthetic cordage .....	33
Fig 2-6-4	Strength reduction factors for age and routing.....	33
Fig 2-6-5	Safety factors .....	33
Fig 2-6-6	Formula for determining SWL.....	34
Fig 2-6-7	Field calculation method for determining MBS.....	34
Fig 2A-1	Comparative qualities of natural and synthetic cordages .....	38
Fig 3-1-1	Construction of steel wire rope.....	39
Fig 3-1-2	Right and left regular lays.....	40
Fig 3-1-3	Right hand lay.....	41
Fig 3-1-4	Left hand lay.....	41
Fig 3-1-5	Arrangement of strands in wire rope.....	42
Fig 3-2-1	Coiling onto reels .....	43
Fig 3-2-2	Uncoiling steel wire rope.....	44
Fig 3-2-3	Whipping of steel wire ropes .....	45
Fig 3-2-4	Kinking of wire rope.....	45
Fig 3-2-5	Worming, parcelling and serving.....	46
Fig 3-3-1	Hawser bend .....	48
Fig 3-3-2	Two half hitches .....	48
Fig 3-3-3	Carrick bend .....	48
Fig 3-3-4	Bulldog grip clamp .....	49
Fig 3-3-5	Eye on SWR formed with bulldog grip clamps .....	49
Fig 3-3-6	Required Number of Fittings .....	50
Fig 3-3-7	Strength Factors of Various Fittings .....	50
Fig 3-3-8	Double-throated clamp .....	50
Fig 3-3-9	Double base clamp .....	50
Fig 3-3-10	Thimbles.....	51
Fig 3-3-11	Safe Working Loads for Shackles .....	51



Fig 3-3-12	Hook inspection areas .....	52
Fig 3-3-13	Effect of eccentric loads on hook capacity .....	52
Fig 3-3-14	Throat opening .....	52
Fig 3-4-1	Measuring SWR .....	53
Fig 3-4-2	Planning Guide to Weight and MBS of SWR .....	54
Fig 3-4-3	Steel Wire Rope Reduction Factors .....	55
Fig 3-4-4	Formula for Determining the SWL for SWR .....	55
Fig 3-4-5	SWR Safety Factors .....	55
Fig 3-4-6	Field Formula for Safe Working Load .....	56
Fig 3A-1	Safe working loads of eye, shank, and swivel hooks .....	57
Fig 3A-2	Safe working loads of chain slip hooks.....	58
Fig 3A-3	Characteristics of chain grab hooks .....	58
Fig 3A-4	Characteristics of sliding choker hooks .....	59
Fig 3B-1	Characteristics of SWR.....	61
Fig 4-1	Short link chain.....	62
Fig 4-2	Long link chain.....	63
Fig 4-3	SWL of Chain.....	64
Fig 4-4	Inspecting for chain stretch.....	65
Fig 4-5	Inspecting chain links for gauges, chips and cuts .....	66
Fig 4-6	Inspect all chain links for wear at the bearing surface .....	66
Fig 4-7	Table of compensation for chain wear.....	67
Fig 5-1	Single vertical, choker and basket hitch (vertical legs).....	70
Fig 5-2	Single and Double Basket Hitches.....	71
Fig 5-3	Choker hitches .....	72
Fig 5-4	Load distribution in differing sling leg angles .....	73
Fig 5A-1	SWL of manila cordage slings .....	75
Fig 5A-2	SWL of synthetic fibre cordage slings .....	76
Fig 5A-3	Nylon and dacron web slings .....	77
Fig 5A-4	Maximum SWL of chain and metal slings .....	78
Fig 5A-5	Maximum SWL for 6 x 19 wire rope slings.....	79
Fig 5A-6	Maximum SWL for 6x 37 wire rope slings.....	80
Fig 6-1	Tree and picket holdfast combination.....	81
Fig 6-2	Tree baulk holdfast .....	82
Fig 6-3	Method of withdrawing pickets .....	83
Fig 6-4	Anchor earth holdfast in four vee configuration .....	84
Fig 6-5	Anchor earth holdfast configurations.....	84
Fig 6-6	Surface baulk anchorage.....	85
Fig 6-7	Buried baulk anchorage .....	86
Fig 6-8	Buried anchorages .....	87
Fig 6-9	Shear Stress .....	87
Fig 6-10	Bending Moment .....	88

Fig 6-11	Effective Area of a Buried Baulk Anchor.....	88
Fig 6-12	Safe soil resistance (r) of earth face in a buried anchorage..	89
Fig 6-13	Buried anchorage soil factors.....	89
Fig 6-14	Safe pull on buried anchor .....	89
Fig 6-15	Straight pull rock anchorage .....	91
Fig 6-16	Cable Selection Data.....	94
Fig 6-17	Slope ratio in level ground.....	95
Fig 6-18	Slope ratio in rising ground.....	95
Fig 6-19	Slope ratio in falling ground .....	96
Fig 6-20	Corrected slope ratio.....	96
Fig 6-21	Tower offset.....	97
Fig 6A-1	Design calculations for buried anchorages.....	100
Fig 6B-1	Construction site diagram.....	103
Fig 7-1-1	Lifting and running Tackles.....	104
Fig 7-1-2	Types of blocks.....	106
Fig 7-1-3	Parts of a snatch block .....	106
Fig 7-2-1	Correct and incorrect sheaves for a rope .....	108
Fig 7-2-2	Reeving tackles .....	109
Fig 7-2-3	Horizontal tackle anti-twister.....	110
Fig 7-2-4	Vertical anti-twister .....	110
Fig 7-2-5	Lashing a block to a spar .....	110
Fig 7-2-6	Mousing a hook .....	111
Fig 7-2-7	Alternate method of mousing a hook.....	111
Fig 7-3-1	Formula for determining the mechanical advantage of tackles.....	112
Fig 7-3-2	Number of returns of the fall at the moving block.....	112
Fig 7-3-3	Commonly used tackles .....	113
Fig 7-3-4	Coefficient of friction .....	113
Fig 7-3-5	Required pull formula.....	113
Fig 7-3-6	SWL of blocks .....	114
Fig 7-3-7	Pull on anchors .....	114
Fig 7-3-8	Number of turns required.....	115
Fig 7-3-9	The pull on a leading block .....	115
Fig 7A-1	Proforma for tackle systems design.....	118
Fig 8-1-1	Standing derrick with a split back guy.....	119
Fig 8-1-2	Methods of raising and lowering a derrick .....	120
Fig 8-2-1	Sheers .....	122
Fig 8-2-2	Force Induced in Spars and Guys by Loads.....	123
Fig 8-2-3	Maximum load (kN) on spars of various lengths and diameters .....	124

Fig 8-3-1	Gyn.....	126
Fig 9-1	Simple elevated cable .....	128
Fig 9-2	Travellers for elevated cables .....	129
Fig 9-3	Top end arrangement of elevated cable .....	130
Fig 9-4	Maximum concentrated loads on suspended cable .....	130
Fig 9-5	Unloaded tension of suspended cables .....	131
Fig 9A-1	Design proforma for field machines .....	143

## **CHAPTER 1**

### **INTRODUCTION**

#### **GENERAL**

1-1. Engineers can complete a wide variety of rigging tasks ranging from the construction of elevated cableways to the erection of engineer field machines. To carry out these tasks the sapper must master numerous skills and techniques.

1-2. The majority of an engineer's tasks will have established procedures, but all too often the tools and equipment available will not be the most suitable. To succeed, the sapper must depend on flexibility, imagination and the application of common fundamental rigging skills and data, and improvise to achieve the desired results.

1-3. In many operational scenarios there will be little or no time to consult reference books. This manual establishes the basic skills with which the individual sapper, through training and practice, shall be conversant, and provides a reference for the project planner and supervisor.

#### **AIM**

1-4. The aim of this manual is to provide information on the procedures, methods and skills required to complete fundamental rigging tasks and to provide data necessary for the safe design of field machines and rigged systems.

#### **SCOPE**

1-5. This publication is designed to be a comprehensive reference for the individual field engineer and assault pioneer, as well as their supervisors. This manual does not duplicate or eliminate the requirement for equipment operator manuals. This manual covers the following:

- a. ropes and cordage;
- b. knots, bends, hitches, splices and lashings;
- c. steel wire rope (SWR);
- d. clamps, fastenings, hooks, chains and shackles;

## Rigging

- e. slings;
- f. anchorages;
- g. block and tackle systems;
- h. field machines; and
- j. elevated cableways.

## REFERENCES

1-6. The following publications are related to and may be used in conjunction with this manual:

- a. B-GL-320-002/PT-001, Engineer and Assault Pioneer Pocketbook (April 1989);
- b. B-GL-320-003/PT-001, Engineer Planning and Organization of Work (August 1973);
- c. B-GL-050-ENG/FT-085, Volume II, Pamphlet No 1, Basic Field Engineering (1974);
- d. R-GG-F05-034/FP-000 (FM 5-34) US Engineering Field Data;
- e. C-83-050-001/MD-000 (FM 5-725) Rigging (October 1968);
- f. 13-146-11 Construction Safety Association of Ontario Rigging Manual; and
- g. B-GL-320-004/FP-001, Engineer Field Manual, Volume 4, Basic Field Engineering.

## DIMENSIONS

1-7. Metric units and formulae are used throughout the manual, although in some cases imperial units are also given because of measurements used by manufacturers. Annex A to this chapter contains conversion tables between metric and imperial units of measure.

## ANNEX A

## IMPERIAL-METRIC CONVERSION TABLES

## MEASUREMENTS OF LENGTH

Unit	Abbreviation	Equivalent	Conversion
millimetre	Mm	0.001 m	0.03937 in
centimetre	Cm	0.01 m	0.3937 in
metre	M	1 m	3.2808 ft
			1.0946 yds
kilometre	Km	1000.0 m	3280.84 ft
			0.54 nautical miles
			0.6214 statute miles
inch	In	1/12 ft	25.4 mm
foot	Ft	12 in	0.3048 m
yard	Yd	3 ft	0.9144 m
statute mile		1760 yds	1.609344 km
		5280 ft	

Fig 1A-1 Linear measures

## MEASUREMENT OF AREA

Unit	Abbreviation	Equivalent	Conversion
sq mm	mm <sup>2</sup>	0.000001 m <sup>2</sup>	0.00155 in <sup>2</sup>
sq cm	cm <sup>2</sup>	0.001 m <sup>2</sup>	0.155 in <sup>2</sup>
sq m	m <sup>2</sup>	1 m <sup>2</sup>	10.764 ft <sup>2</sup>
			1.196 yd <sup>2</sup>
hectare	ha	10,000 m <sup>2</sup>	2.471 acres
sq km	km <sup>2</sup>	1,000,000 m <sup>2</sup>	247.1 acres
		100 ha	0.3861 mile <sup>2</sup>
sq in	in <sup>2</sup>	1/144 ft <sup>2</sup>	6.4516 cm <sup>2</sup>
sq ft	ft <sup>2</sup>	144 in <sup>2</sup>	0.0929 m <sup>2</sup>
acre			0.0040 km <sup>2</sup>
			0.4047 ha
sq mile	mile <sup>2</sup>	640 acres	2.59 km <sup>2</sup>
			258.99 ha

Fig 1A-2 Surface measures

MEASUREMENT OF CAPACITY

Unit	Abbreviation	Equivalent	Conversion
millilitre litre	mL L	0.001 L 1 L	0.0351 fluid oz 1.7598 pts 0.8799 qt 219.9736 gals
kilolitre cubic centimetre cubic metre	kL cm <sup>3</sup> m <sup>3</sup>	1000 L	0.0610 in <sup>3</sup> 35.3147 ft <sup>3</sup> 1.3080 yds <sup>3</sup> 0.0008 acre ft
cubic kilometre	km <sup>3</sup>		0.25 mile <sup>3</sup>
fluid ounce pint quart gallon (imperial) gallon (US) cubic foot	fl oz pt qt gal gal (US) ft <sup>3</sup>	<sup>1</sup> / <sub>160</sub> gal <sup>1</sup> / <sub>8</sub> gal <sup>1</sup> / <sub>4</sub> gal 1.201 gal 6.23 gal	0.0284 litre 0.5682 litre 1.1365 litres 4.5460 litres 3.785 litres 28.2161 litres

Fig 1A-3 Volume capacity

MEASUREMENT OF WEIGHT

Unit	Abbreviation	Equivalent	Conversion
milligram gram	mg g	0.001 g 1 g	0.0154 grain 15.43 grains
kilogram	kg	1000 g	0.03527 oz 2.204623 lbs
tonne	t	1000 kg	0.022 cwt 2205 lbs 1.1023 short tons
ounce pound hundredweight long ton	oz lb cwt T	16 oz 100 lbs 2240 lbs	28.3495 g 453.59 g 0.453 kg 45.359 kg
short ton	T(US)	2000 lbs	1016.04 kg 1.0160 T 907.18 kg 0.9072 T

Fig 1A-4 Weight measure

## MEASUREMENT OF FORCE

Unit	Abbreviation	Conversion
Newton	N	0.2248 lbf
Kilonewton	kN	0.1004 tonf
kilogram force – Newton	N	0.2248 kip 0.1020 kgf
pound force	lbf	4.448 N
ton force	tonf	9.964 kN
1000 pound force	kip	4.448 kN

Fig 1A-5 Force

## MEASUREMENT OF MASS PER UNIT LENGTH

Unit	Abbreviation	Conversion
kilogram per meter	kg/m	0.0672 lb/ft 2.016 lb/yd
pound per foot	lb/ft	1.488 kg/m
pound per yard	lb/yd	0.4961 kg/m

Fig 1A-6 Mass per unit length

## MEASUREMENT OF MASS PER UNIT AREA

Unit	Abbreviation	Conversion
kilogram per square meter	kg/m <sup>2</sup>	0.001422 lb/in <sup>2</sup> 0.2048 lb/ft <sup>2</sup>
pound per square inch	lb/in <sup>2</sup> (psi)	703.1 kg/m <sup>2</sup>
pound per square foot	lb/ft <sup>2</sup>	4.882 kg/m <sup>2</sup>

Fig 1A-7 Mass per unit area

## MEASUREMENT OF MASS PER UNIT VOLUME

Unit	Abbreviation	Conversion
kilogram per cubic metre	kg/m <sup>3</sup>	0.00003606 lb/in <sup>3</sup> 0.0624 lb/ft <sup>3</sup> 1.686 lb/yd <sup>3</sup>
pound per cubic inch	lb/in <sup>3</sup>	27.680 kg/m <sup>3</sup>
pound per cubic foot	lb/ft <sup>3</sup>	16.02 kg/m <sup>3</sup>
pound per cubic yard	lb/yd <sup>3</sup>	0.5933 kg/m <sup>3</sup>

Fig 1A-8 Mass per unit volume



MEASUREMENT OF STRESS AND PRESSURE

Unit	Abbreviation	Equiv.	Conversion
pound per square inch	lb/in <sup>2</sup>		0.006895 MPa
ton per square inch	ton/in <sup>2</sup>		6.895 kPa (N/mm <sup>2</sup> x10 <sup>-3</sup> )
1000 pound per square inch	lb/in <sup>2</sup>		15.44 MPa (N/mm <sup>2</sup> ) 6.895 MPa (N/mm <sup>2</sup> )
kilopascal	kPa	N/mm <sup>2</sup> x 10 <sup>-3</sup>	0.06476 tonf/in <sup>2</sup>
megapascal	Mpa	N/mm <sup>2</sup>	0.145 lbf/in <sup>2</sup> 145.0 lbf/in <sup>2</sup>

Fig 1A-9 Stress and pressure

METRIC PREFIXES

Prefix	Represents	The Unit is Multiplied by
tera	one trillion	1,000,000,000,000
giga	one billion	1,000,000,000
mega	one million	1,000,000
hectokilo	one hundred thousand	100,000
myria	ten thousand	10,000
kilo	one thousand	1,000
hecto	one hundred	100
deca	ten	10
		1
deci	one tenth	0.1
centi	one hundredth	0.01
milli	one thousandth	0.001
decimilli	one ten thousandth	0.0001
centimilli	one hundred thousandth	0.00001
micro	one millionth	0.000001
nano	one billionth	0.000000001
pica	one trillionth	0.000000000001

Fig 1A-10 Meaning of metric prefixes

**CONVERSION TABLES**

From	To	Multiply by
<b>Lengths and Distances</b>		
miles	kilometres	1.6093
miles	feet	5280.0
nautical miles	feet	6080.27
feet	metres	0.3048
inches	centimetres	2.54
kilometres	miles	0.6214
kilometres	feet	3280.840
metres	feet	3.808
	inches	39.37
<b>Areas</b>		
sq miles	sq kilometres	2.59
sq miles	acres	640
sq feet	sq metres	0.0929
acres	sq feet	43,560
sq kilometres	sq miles	0.3861
hectares	sq metres	10,000
hectares	acres	2.47
<b>Volumes</b>		
cu feet	imperial gals	6.23
cu feet	cu metres	0.0283
cu meters	cu feet	35.31
cu miles	acre feet	3,379,200
cu miles	cu metres	4,168,260,100
acre feet	cu metres	1,233.50
acre feet	imperial gals	272,250.0
imperial gals	litres	4.5460
US gals	litres	3.7853
litres	imperial gals	0.2201
<b>Weights</b>		
pounds	kilograms	0.4536
kilograms	pounds	2.2046

Fig 1A-11 Conversion tables

## CHAPTER 2

### CORDAGE

#### SECTION 1

#### TYPES OF CORDAGE

##### GENERAL

2-1-1. The dictionary term Arope≡ includes both fibre and wire rope. In military engineering the term rope refers to steel wire rope, and rope made from vegetable (natural) or synthetic fibres is called Acordage”.

2-1-2. **Lay.** The fibres of cordage may be either twisted or woven (braided) together. In most cordage, the fibres are twisted together to form a yarn, several yarns are twisted together in the opposite direction to form a strand. Three or more strands are twisted together in the original direction again to form the cordage. The direction in which the strands are twisted together determines the ALay≡ of the cordage, strands being laid either left or right handed. Normal service cordage is three strand, right hand lay and is termed Hawser Lay.

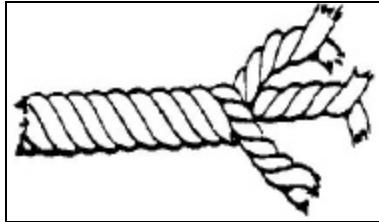

Fig 2-1-1 Hawser Lay cordage

2-1-3. The fibres of cordage may either be staple or continuous. Staple fibre cordage is manufactured from short fibres, while in continuous fibre cordage, the fibres run the full length of the rope. All natural fibre cordage is staple fibre. Most synthetic cordage is continuous fibre and the strength increases with staple length.

##### IDENTIFICATION OF CORDAGE

2-1-4. The different types of natural and synthetic fibre cordage are described in this section. The comparative qualities are shown at Annex A to this chapter. Coloured yarn is incorporated into the weave of cordage because correct identification is necessary for the determination of cordage strength. The standard fibre identification colour code is set out below.

## IDENTIFICATION COLOURS OF FIBRE CORDAGE

Ser	Type of cordage fibre	Colour code identifying yarn
(a)	(b)	(c)
1	Manila	Black
2	Sisal	Light blue
3	Nylon	Red
4	Polyester	Green
5	Polypropylene	Red-brown

Fig 2-1-2 Fibre identification colour coding table

**VEGETABLE FIBRES**

2-1-5. **Manila.** Manila cordage is manufactured from the leaf stalk of the banana plant and varies in colour from a yellow-white to dark brown, the lighter shades producing the best cordage. Manila is the strongest of all vegetable fibre cordage, has good resistance to wear and deterioration, is smooth and runs well over blocks and sheaves.

2-1-6. **Sisal.** Sisal cordage is white and has about 80 percent of the strength of high quality manila. It has a coarse feeling. Sisal cordage stands exposure to sea water very well and for this reason is commonly used in port and dock installations.

2-1-7. **Hemp and Coir.** Cordage made from hemp and coir is not as strong as that made from manila or sisal and is no longer manufactured, However some stocks still exist and are used by other nations.

**SYNTHETIC FIBRES**

2-1-8. **Synthetic Fibre Cordage.** The synthetic fibres used in cordage manufacture are made from plastic materials and are stronger, though more elastic, than natural fibres.

2-1-9. **Nylon.** Nylon cordage is the most common and strongest synthetic fibre cordage in service use, but is also the most elastic. It is difficult to untie after strain has been applied, and care should be taken in the choice of knots. The natural colour is white, but it may be colour dyed.

2-1-10. **Polyester.** Polyester cordage is second in strength to nylon but is not as elastic. Unlike most other synthetics, it is very resistant to the

## Rigging

effects of sunlight and is well suited for use in exposed situations such as tie down ropes on vehicle tarps.

2-1-11. **Polypropylene.** Polypropylene is not widely used in the service. It is similar in strength to polyester but, unlike the majority of the synthetics, it has the advantage of being buoyant.

## SECTION 2

### CARE OF CORDAGE

#### GENERAL

2-2-1. The strength and useful life of cordage is considerably reduced by improper care. Natural fibre cordage shrinks when wet and is susceptible to rot and mildew. Synthetic fibre is sensitive to heat and can be damaged by friction. All cordage deteriorates through long exposure to direct sunlight, and is reduced in strength by sharp bends, kinks and sudden, or impact stresses. The fibre of cordage is easily worn or cut by rubbing on sharp edges. Similarly, if grit works its way between the fibres, it acts as an internal abrasive. Cordage shall be stored correctly, handled carefully and inspected frequently.

2-2-2. **Storage.** Cordage will be stored in a cool, dry place with adequate ventilation. It shall be coiled and placed on racks or hung from hooks to allow for circulation of air. Store cordage out of direct sunlight and away from paint, fuel or strong chemicals as the fumes can weaken the fibres. Because natural fibre cordage is susceptible to rot and mildew it shall be thoroughly dried before storing. Cordage must never be force dried. Cordage swells when wet and shrinks as it dries. If a rope is tensioned when wet, such as a guy, it will over-tension as it dries. Care is required to prevent this from occurring.

2-2-3. **Coiling Cordage.** Before cordage is stored it shall be wound onto a spool or formed into a loose coil. It is always coiled with the lay, that is, in a clockwise direction for right hand lay. For short lengths of cordage a loose coil is formed in the hands as shown in Fig 2-2-1. When coiling longer lengths on the ground when a drum or reel is not available, ensure that dirt and twigs are not caught between the fibres, and the cordage is coiled around pickets driven into the ground. For comparatively short lengths of light cordage, set the pickets on the circumference of the circle and wind the cordage around making sure all kinks are removed. Larger pieces of cordage that are difficult to handle can be coiled around pickets in the shape of a figure-of-eight which prevents the formation of kinks. When the coiling is complete, the coil is secured in at least three places with light cordage or twine.

2-2-4. **Uncoiling New Cordage.** New cordage is produced either in a coil or wound on a spool or drum. A coil comes in a protective wrapping

## Rigging

which is bound with twine. Cordage is unwound from the centre of the coil. To do this, remove enough of the outer wrapping so that the end of the cordage can be reached, place the coil so that the end is to the bottom, cut any twine bindings, reach down through the centre of the coil and draw the end of the cordage upwards. A partly used coil is handled carefully and left in its protective wrapping. Spools or drums are suspended on a bar and carefully unreeled. If these procedures are not followed, the cordage will twist and kinks will result.

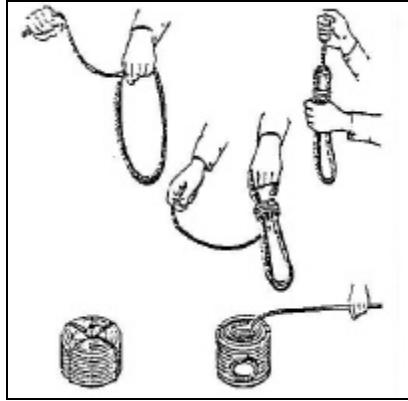

Fig 2-2-1 Coiling and uncoiling cordage

### WHIPPING OF CORDAGE

2-2-5. Cordage ends unravel unless preventative measures are taken. Unravelling of synthetic cordage may be prevented by melting the loose ends. Unravelling may be prevented by the use of a stopper knot, by taping the loose ends, by backsplicing or by whipping. Whipping is binding loose ends with twine. Two methods are shown in Fig 2-2-2 and Fig 2-2-3. The length of whipping shall be twice the diameter of the cordage. Whipping can also be used to prevent cordage unravelling further than required when splicing. The advantage of whipping is that it only slightly increases the diameter of the cordage, thus it can still pass through blocks, thimbles and eyes. It is good practice when cutting cordage to place two whippings on the cordage and cut between them

### PARCELLING CORDAGE

2-2-6. When cordage is likely to chafe it shall be parcelled at any point where this may occur. Parcelling involves wrapping the cordage with strips of canvas or hessian and then binding it with tape or twine. Alternatively, a length of plastic or rubber hose can be used.

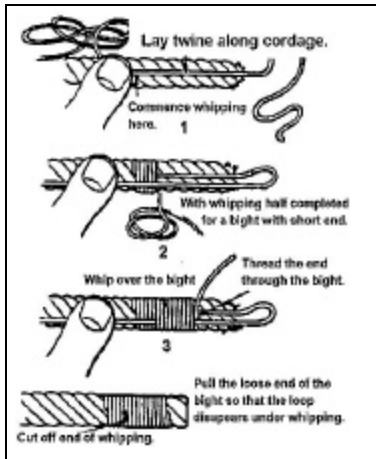

Fig 2-2-2 A method of whipping

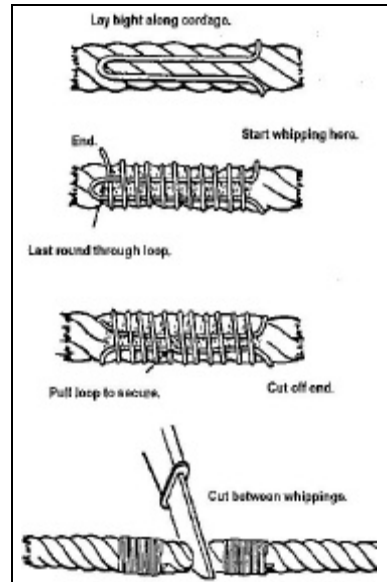

Fig 2-2-3 An alternate method of whipping

## INSPECTION OF CORDAGE

2-2-7. The strength of cordage is reduced with use and age. Frequent inspection is necessary to determine if cordage is to be replaced and to prevent damaged cordage from being used. Natural fibre cordage shows obvious signs of age and damage such as discoloration, bleaching and parting of the outer fibres. Synthetic cordage wear is less obvious.

2-2-8. When checking cordage for damage, inspect about a metre at a time and turn the cordage over so that all strands are inspected. External wear is indicated by chafed, broken or frayed yarns. Cordage may appear sound externally but may be damaged internally. To check this untwist the strands carefully so as not to cause kinks, and look for flattened fibres, powdered fibres or grit. Rot or mildew will be indicated by a musty odour and the inner fibres will have a dark stained appearance.

2-2-9. Localized damage can be cut out and the cordage can be rejoined by splicing. Cordage with large areas of damage shall be destroyed.



### SECTION 3

## KNOTS, BENDS AND HITCHES

### GENERAL

2-3-1. Generally, a knot, bend or hitch will hold without slipping. Knots shall be easy to tie and, more importantly, easy to untie. The choice of a knot will depend largely on the job it will do and sappers shall be conversant with the intended uses of the more common knots. Remember that a knot may reduce the strength of cordage by up to one half its strength. The most common knots are described and illustrated in this section. The related terms of knots, bends and hitches are illustrated below.

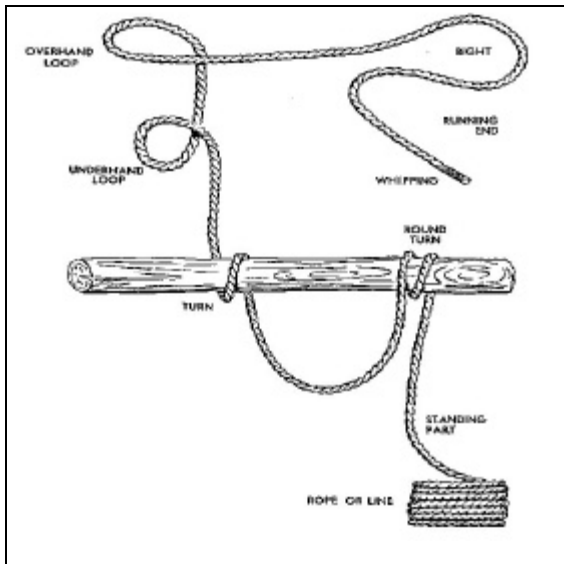

Fig 2-3-1 Terminology when using cordage

2-3-2. **Lay.** Any two lengths of cordage can be joined by a knot. Right hand laid cordage shall not be joined to left hand laid cordage, as the two pieces of cordage will tend to unlay when tension is applied. A difference in the lay of cordage will be obvious if the two ropes are held side by side. The cordage will be similar in lay if the strands run parallel.

2-3-3. The following pages describe the knots, bends and hitches in common field engineering use and their application.

### SEIZING AND FRAPPING

2-3-4. Seizing and Frapping is used to further secure or finish a knot such as a hitch, or Fisherman=s Bend. Bend.

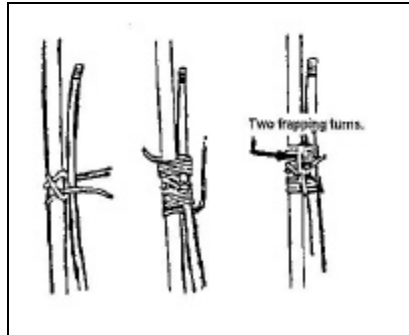

Fig 2-3-2 Seizing and frapping

- a. **Seizing.** When tying a knot, always leave enough spare end to ensure that the running end cannot pull out of the knot when stress is applied. To make the knot more secure and as a part of hitches such as the Fisherman=s Bend, the running end of the cordage is seized to the standing part of the cordage.
- b. **Frapping.** Frapping turns are turns laid on a knot or lashing at right angles to tighten the seizing turns.

### STOPPER KNOTS FOR CORDAGE

2-3-5. **Thumb Knot.** The thumb knot is used at the end of cordage as a temporary method to prevent it from unravelling or as a stop knot to prevent it from slipping through a block or ring. A thumb knot is hard to untie, particularly if tensioned when wet.

2-3-6. **Figure of Eight Knot.** The figure of eight knot is larger than the thumb knot but is used for the same purposes. It increases in size and strength when stressed against a block and is easier to untie.

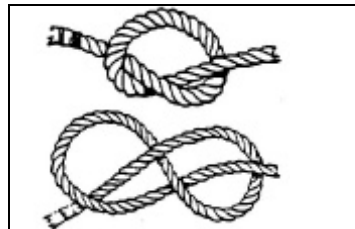

Fig 2-3-3 Thumb knot (top) and figure of eight knot (bottom)

**KNOTS JOINING TWO LENGTHS OF CORDAGE**

2-3-7. **Reef Knot.** A reef knot is used as a binding knot where it is pressed against a surface. It is often incorrectly used to join two pieces of cordage; this practice is dangerous as it may change its form, one piece of cordage becoming straight and the other forming two reversed half-hitches (girth hitch). Note that in the finished knot, the standing and running ends of each piece of cordage lie together on the same side of the loop in the other lashing, and also that the two running ends appear on the same side of knot.

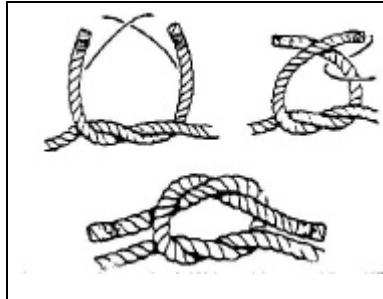

Fig 2-3-4 Reef knots

2-3-8. **Granny and Thief Knots.** These two knots which resemble a reef knot, are used to join two pieces of cordage of equal or nearly equal size. Note that in the diagram, R is the running end and S is the standing end.

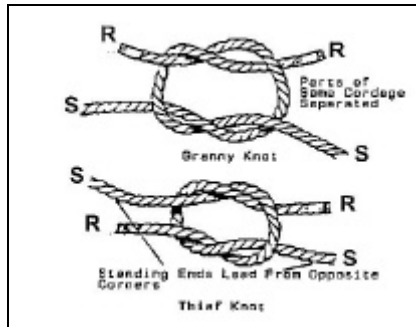

Fig 2-3-5 Granny and thief knots

2-3-9. **Double Sheet Bends.** A double sheet bend is used to join two pieces of cordage of unequal size.

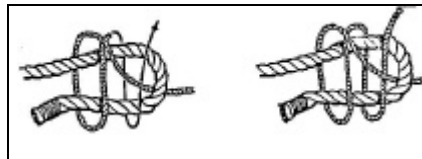

Fig 2-3-6 Double sheet bends

2-3-10. **Hawser Bends.** The hawser bend is used for joining very large cordage or steel wire ropes (Fig 2-3-7).

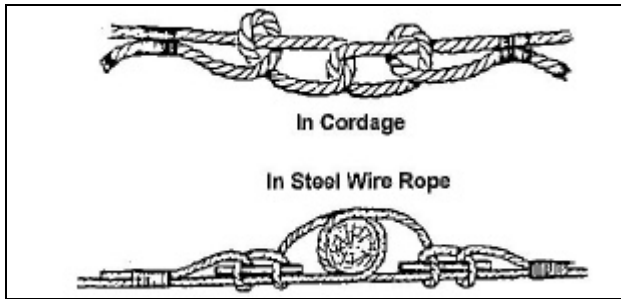

Fig 2-3-7 Hawser bend

2-3-11. **Carrick Bend.** The carrick bend is used for joining two lengths of cordage together. It will not draw tight if both running ends are seized to their respective standing ends.

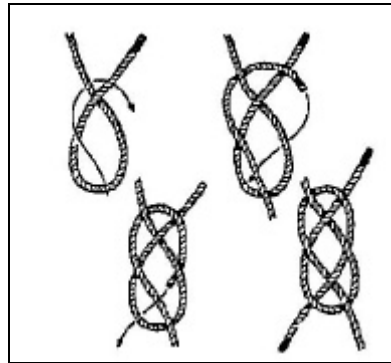

Fig 2-3-8 Carrick bend

### KNOTS SECURING CORDAGE TO A SPAR, HOOK OR RING

2-3-12. **Timber Hitch.** A timber hitch and half hitch are used to fix cordage to a spar for towing purposes. The advantage of this knot is that the heavier the pull, the tighter the hitch grips. As soon as the tension is relieved, the knot can be easily untied.

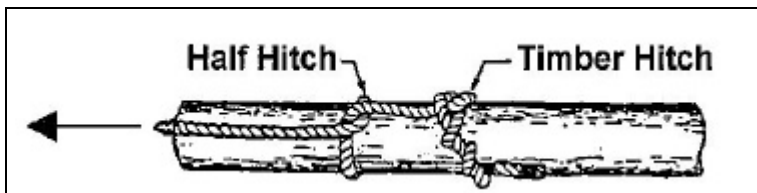

Fig 2-3-9 Timber hitch

2-3-13. **Clove Hitch.** A clove hitch is used to start and finish lashings.

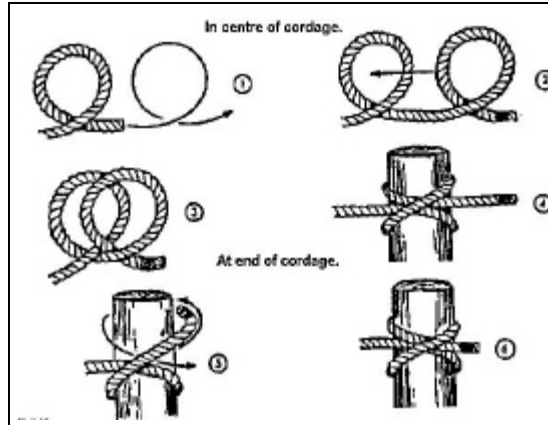

Fig 2-3-10 Clove hitch

2-3-14. **Round Turn and Two Half Hitches.** A round turn and two half hitches is used to secure cordage to an anchorage. The half hitches, made with the running end on the standing end, must form a clove hitch but should be left separated. If they do not, then the second half hitch has been formed wrong. The running end shall always be seized to the standing end of the cordage.

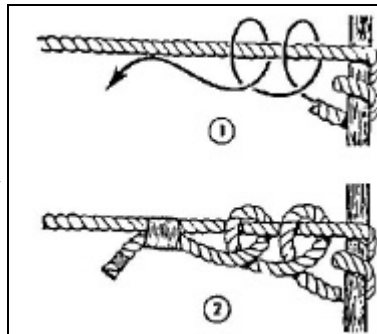

Fig 2-3-11 Round turn and two half hitches

2-3-15. **Fisherman's Bend.** The fisherman's bend is used to secure cordage where there is a give and take motion, for example securing a breastline from a boat to a dock dollard or a ring. It is similar to a round turn and two half hitches except that the first half hitch is taken through the round turn.

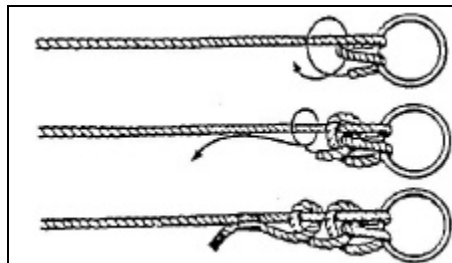

Fig 2-3-12 Fisherman's bend

2-3-16. **Draw Hitch.**

The draw hitch is used to secure cordage to a ring or rail. It can be released instantly by pulling on the running end which will cause the cordage to fall away.

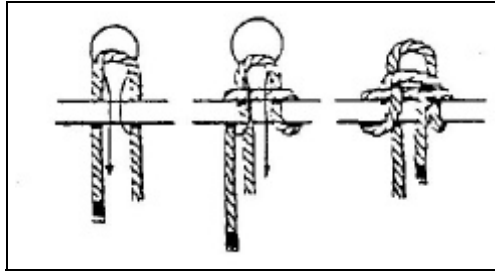

Fig 2-3-13 Draw hitch

2-3-17. **Rolling Hitch.** The rolling hitch is used to secure one piece of cordage to another or to fasten cordage to a pole or pipe so that it will not slip. The knot grips tightly but slides easily along the cordage or pole when the strain is relieved.

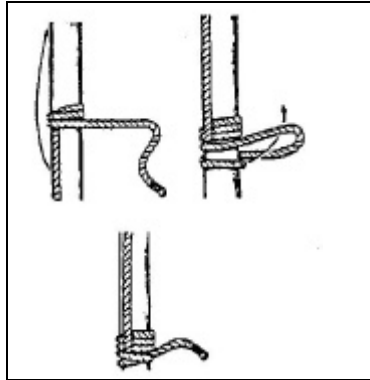

Fig 2-3-14 Rolling hitch

2-3-18. **Stopper Hitch.** The stopper hitch is a more secure form of the rolling hitch and is used to transfer strain from one piece of cordage to another.



Fig 2-3-15 Stopper hitch

2-3-19. **Lever Hitch.** The lever hitch is used for getting a grip on cordage with a bar or pole, such as using a pole to drag a hawser. It is also used to fix the rungs to a rope ladder.

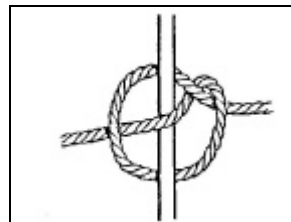

Fig 2-3-16 Lever hitch

## KNOTS FORMING LOOPS IN CORDAGE

2-3-20. **Bowline.** The bowline forms a single loop in cordage that will not tighten or slip under strain, but is easily untied.

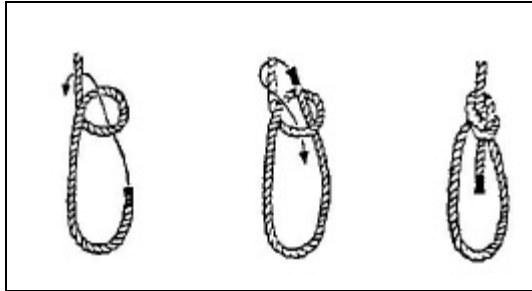

Fig 2-3-17 Bowline

2-3-21. **Running Bowline.** The running bowline provides a running loop. It consists of a small bowline made around the standing end of cordage.

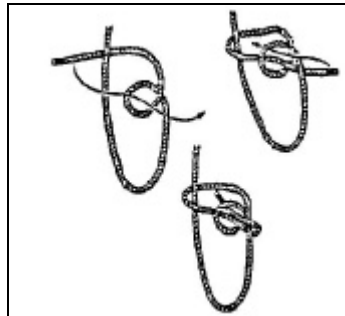

Fig 2-3-18 Running bowline

2-3-22. **Double Bowline.** The double bowline forms three non-slipping loops. This knot can be used for slinging a person seated in the slings, one loop supporting the back, and the remaining two loops supporting the legs. A notched board passed through the two loops makes a comfortable seat known as a boatswain's chair.

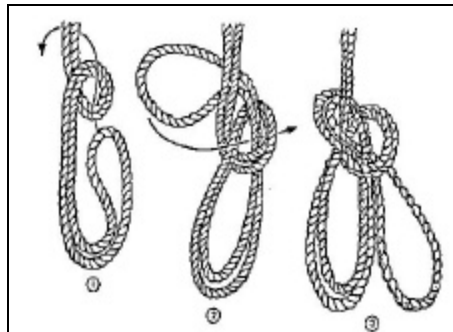

Fig 2-3-19 Double bowline

2-3-23. **Bowline on a Bight.** The bowline on a bight forms a double loop in the middle of cordage. Its main use is to form an improvised boatswain's chair. The user sits in one loop with the other around the back and under the arms

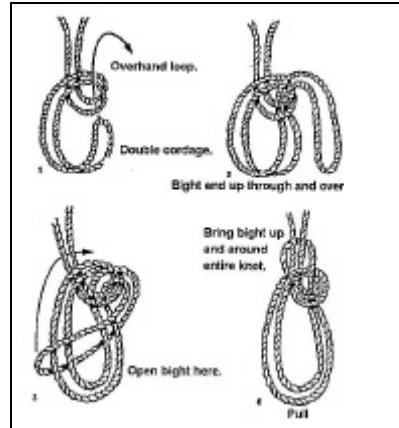

Fig 2-3-20 Bowline on a bight

2-3-24. **Catspaw.** The catspaw is used to secure the centre of a cordage sling to a hook so that it will not slip.

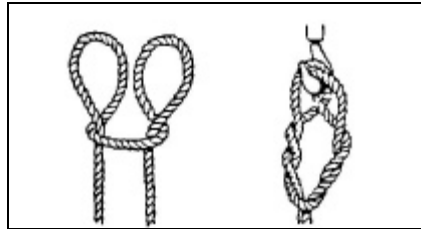

Fig 2-3-21 Catspaw

2-3-25. **Single Blackwall Hitch.** The single Blackwall hitch is used to secure the end of cordage to a hook. Seizing the running ends to the standing end of the cordage will prevent it from slipping when not under a load.

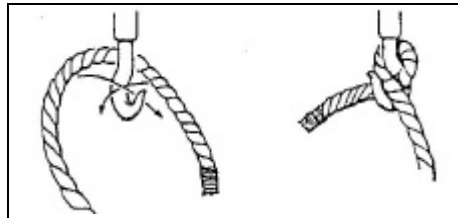

Fig 2-3-22 Single Blackwall hitch

2-3-26. **Double Blackwall Hitch.** The double Blackwall hitch is used the same as a single Blackwall hitch. To prevent slipping when not under a load, seize the running end of the cordage to the standing end.

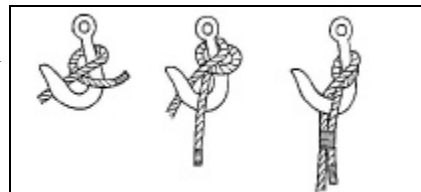

Fig 2-3-23 Double Blackwall hitch



## Rigging

2-3-27. **Harness Hitch.** The harness hitch is used to form a loop that will not slip in the middle of cordage

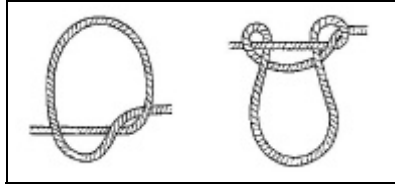

Fig 2-3-24 Harness hitch

### KNOTS TO SHORTEN OR TIGHTEN CORDAGE

2-3-28. **Sheep Shank.** The sheep shank is used to shorten or take the strain off a weak spot in cordage.

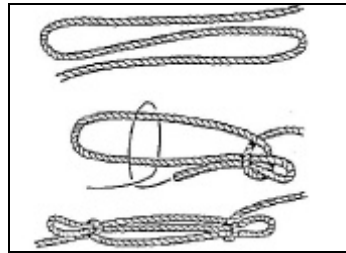

Fig 2-3-25 Sheep shank

2-3-29. **Baker Bowline.** The baker bowline is used to tighten a lashing.

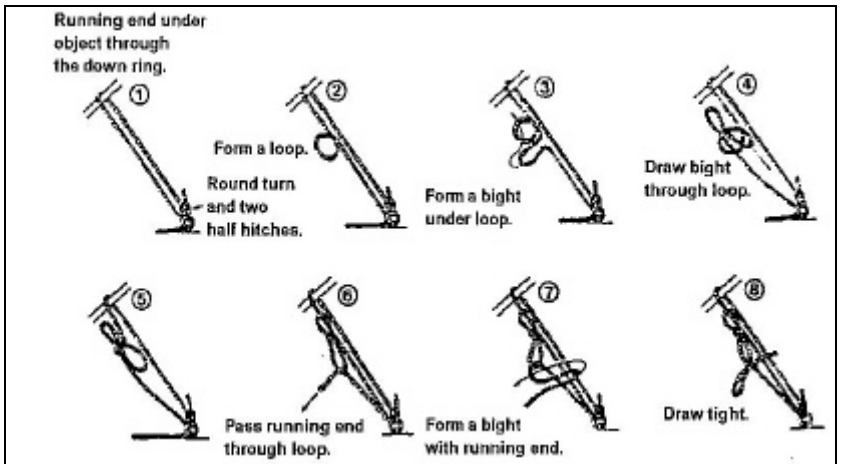

Fig 2-3-26 Baker bowline

## SECTION 4

### SPLICING

#### GENERAL

2-4-1. Splicing is the means whereby cordage can be permanently joined or stopped without using a knot. It involves unlaying the strands and reweaving them into another section of cordage. The four basic splices are the short splice, long splice, eye splice and back splice.

2-4-2. A general rule for the amount of cordage to be unlaid prior to splicing is 40 times the diameter for a long splice, and 8 to 10 times the diameter for all other splices. It is important that the strands are then laid firmly in their new positions so that they all take their share of the load. A good splice will have up to 95 % of the strength of the cordage itself. Because synthetic fibres are slippery in comparison to natural fibres, at least two extra tucks shall be used when splicing them.

2-4-3. When splicing, it is most important to prevent the strands of the running end from unlaying and to avoid kinking the standing part. To prevent the strands from unlaying, the ends shall be bound with a temporary whipping, or with tape, and a conscious effort will always be made to keep the twist in the strand. To avoid kinking the standing part, the strands will be opened carefully. With new cordage splicing may be a two man operation. Proficiency in splicing comes only with practice.

#### SHORT SPLICING

2-4-4. The short splice (Fig 2-4-1) is the strongest method of joining two lengths of cordage. It is used to make a cordage sling, or to join two pieces of cordage that are not required to pass through a block. To make the splice :

- a. unlay the two pieces of cordage the required distance and bind the ends of the strands;
- b. marry the two ends so that the strands of one piece of cordage mesh alternately with the strands of the other. Temporarily seize one set of strands around the other piece of cordage and work on the free strands;

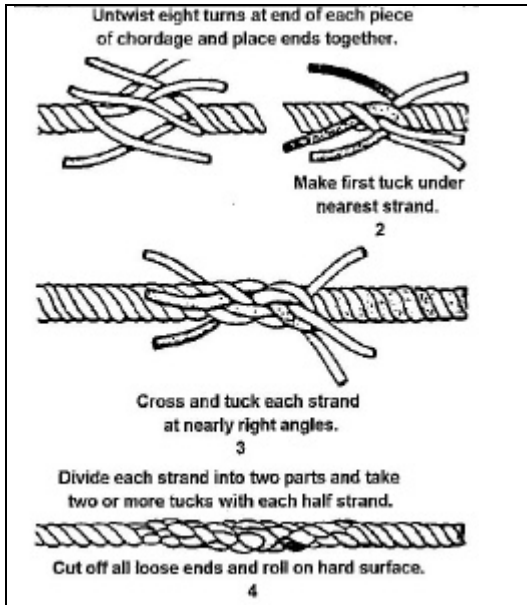

Fig 2-4-1 Short splice

- tuck each free strand into the standing part of the other piece of cordage against the lay, over the opposing strand and under the next, taking care not to kink the standing part;
- turn the splice around, release the seizing, tuck the other ends and pull all the free ends tight;
- working on the original ends, divide each strand in half, and take at least two more tucks with the two halves side by side so that the diameter of the splice is reduced. Pull tight;
- do the same with the other ends;
- roll and work the splice to ensure that all the strands are taking an equal share of the strain. The splice must be so tight that it resists any tendency to kink; and
- cut off any remaining loose ends but leave enough to ensure the tucks will not pull out.

## LONG SPLICING

2-4-5. The long splice has slightly less strength than the short splice but only produces a small increase in the diameter of the cordage. It is used to join two pieces of cordage that are required to pass through a block. To make the splice (Fig 2-4-2):

- a. unlay the two pieces of cordage the required distance and bind the ends of the strands;
- b. marry the two ends as for the short splice and seize two strands of one piece of cordage around the other;
- c. carefully unlay the remaining strand still further and immediately fill up the space left in the standing part with the corresponding strand from the other piece of cordage. Follow this process until only about 300 mm of the fill-in strand is left. Seize these strands;
- d. repeat the above procedure with another pair of strands, this time working in the opposite direction;
- e. leave the remaining pair of strands where they started;
- f. cut back all loose strands to 300 mm and tuck each pair of strands into the other piece of cordage as for the short splice, but with the lay. Taper off as for the short splice by dividing each strand in half and making at least two more tucks; and
- g. finish off as for the short splice.

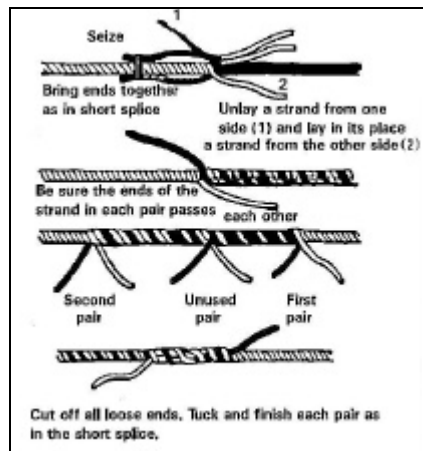

Fig 2-4-2 Long splice

## EYE SPLICES

2-4-6. The eye splice (Fig 2-4-3) is used to make a permanent loop in the end of a piece of cordage. It can be made around a thimble to protect the loop from wear. To make an eye splice

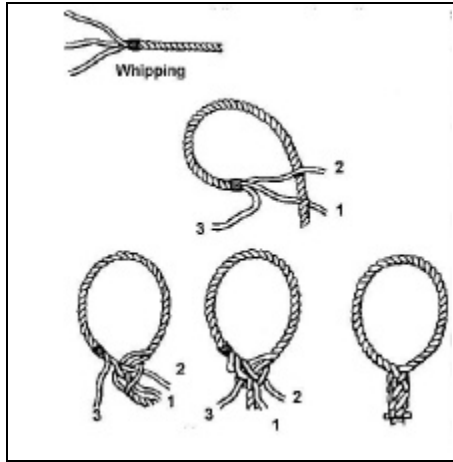

Fig 2-4-3 Eye splice

- a. unlay the cordage the required distance, whip the ends of the strands and whip the cordage at the point where the unlaying stops to prevent the cordage unlaying any further;:
- b. make a counter-clockwise loop of the required size and place the strands over the standing part;
- c. open the standing part at the required position so that two strands are to the left and the other to the right;
- d. pass the centre strand (1) of the running end down through the opening in the standing part and pull down firmly;
- e. take the top strand (2) of the running end, and pass it over the lone strand in the standing part and through and out between the other two strands;
- f. turn the splice over and pass the final strand (3) of the running end back under the remaining strand in the standing part;
- g. the result is symmetrical, with only one free strand from the running end appearing between any two strands in the standing part;
- h. tuck each strand once into the standing part, against the lay, then divide each strand into two parts and complete at least two more tucks with each half-strand, as for the short splice; and

- j. roll and work the completed splice to ensure all strands are taking an equal share of the load, and trim the spare ends as for the short splice.

## BACK SPLICING

2-4-7. The back splice is a method of securing the end of cordage to prevent it from unravelling. To make a back splice:

- a. unlay the cordage the required distance;
- b. make a crown knot and pull down the strands firmly;
- c. select one loose strand and, working against the lay, take it over the adjacent strand immediately below the knot and tuck it under the next one;

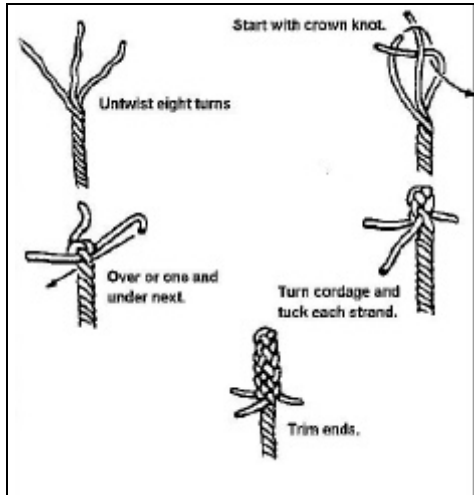

Fig 2-4-4 Back splice

- d. turn the cordage and repeat the action for the other two loose strands; and
- e. give each strand at least one more tuck and trim the spare ends.

## SECTION 5

### LASHINGS

#### GENERAL

2-5-1. Lashings are lengths of cordage used to secure objects to one another. They have many applications in field engineering, for example, in improvised rafting and the construction of field machines. Cordage lashings have a tendency to work loose and therefore require frequent adjustment. SWR is more awkward to use, but its strength and relative inelasticity compared to cordage often make it preferable. SWR shall always be used for lashings in any permanent field structures, as opposed to those constructed for training or for short-term use only.

2-5-2. **Configuration.** Various standard configurations for lashings have been developed for particular tasks. All lashings:

- a. commence and finish with a hitch around one or both of the objects being joined;
- b. consist of a number of turns around the objects being lashed; and
- c. can be tightened by making a number of frapping turns around the lashing between the objects or by driving blunt wooden wedges between the lashing and the objects being joined.

#### STRENGTH AND SIZE OF LASHING

2-5-3. **Strength of Lashings.** The strength of a lashing depends on the strength of the cordage, the number of turns in the lashing and the friction between the lashing and the objects being lashed. However, as the load on a lashing is generally limited by some factor other than the strength of the lashing itself, the minimum size of cordage and the number of turns prescribed for each type of lashing will generally be adequate. All loads shall be applied slowly and carefully. If the lashing slips, more turns are to be added.

2-5-4. **Size of Lashings.** Any size of cordage convenient from a handling point of view may be used for lashings not subjected to load. For lashings subjected to load, for example, the top lashing in shear legs or the lashings for a ledger in a bridge trestle, the minimum allowable diameter

shall be 16 mm for cordage and 10 mm for SWR. Notwithstanding the above, the length and diameter of a cordage lashing to join two spars together can be calculated as follows:

- a. **Length.** For every 25 mm diameter of the larger spar allow 2 m of cordage. For example, a 200 mm diameter spar will require a lashing 16 m in length; and
- b. **Diameter.** The diameter of the cordage shall be about 0.08 (1/12) the diameter of the larger spar. For example, 16 mm cordage shall be used to lash a 200 mm diameter spar.

## TYPES OF LASHING

2-5-5. **Square Lashing.** A square lashing is used to lash one spar to another at right angles.

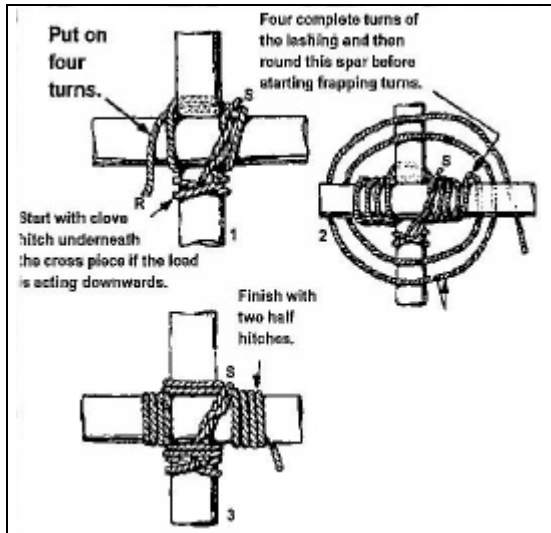

Fig 2-5-1 Square lashing

2-5-6. **Diagonal Lashings.** A diagonal lashing is used to lash two spars together at an angle other than a right angle.

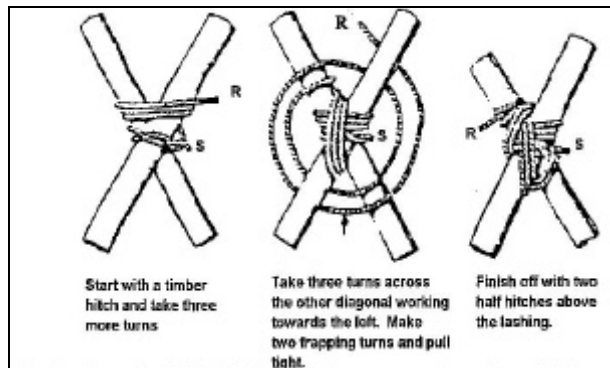

Fig 2-5-2 Diagonal lashing



## Rigging

2-5-7. **Pole Lashing.** A pole lashing is used for lashing two spars lengthwise. Its strength and stability shall always be tested before it is loaded as part of a structure. It is particularly important that the lashing is kept tight. This can best be accomplished by driving wedges made from scrap timber between the splints and the pole. The length of splints shall be 12 times the diameter of the pole.

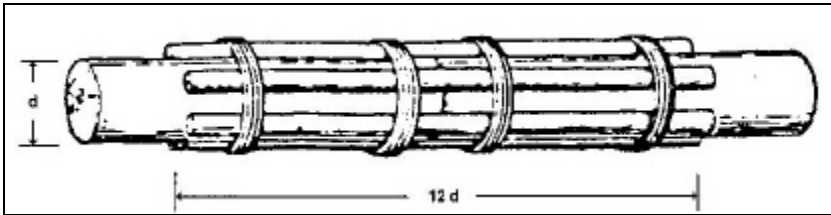

Fig 2-5-3 Pole lashing

2-5-8. **Shear Lashing.** A shear lashing is used to join the two spars of a shear as described in Chapter 8.

2-5-9. **Figure Eight Lashing.** A figure eight lashing is used to join the three spars of a gyn as described in Chapter 8.

2-5-10. **Block Lashing.** A block lashing is used to lash a pulley block to a spar as described in Chapter 8.

## SECTION 6

## CORDAGE STRENGTH

## CORDAGE SIZE AND WEIGHT

2-6-1. **Cordage Size.** The size of cordage is expressed by its diameter in millimetres. The length of a standard coil is 250 m.

2-6-2. **Elasticity.**

Cordage stretches considerably when tensioned. This can be most important in towing or lifting. The approximate percentage of stretch for different types of cordage is shown here.

## CORDAGE ELASTICITY

Ser	Cordage	Approximate Stretch (% of Original Length)
(a)	(b)	(c)
1	Natural Fibre	10 - 20
2	Nylon	46
3	Polyester	25
4	Polypropylene	35

Fig 2-6-1 Elasticity of cordage

2-6-3. **Cordage Weight.** The standard weights for new 100 m lengths of natural fibre and synthetic cordage are given in Fig 2-6-2. Small variations will occur depending on age, weather conditions and degree of saturation.

## WEIGHT OF NATURAL AND SYNTHETIC CORDAGE

Ser	Cordage Size (mm)	Natural Fibre	Nylon	Polyester	Polypro- pylene
		Wt per 100m (kg)	Wt per 100m (kg)	Wt per 100m (kg)	Wt per 100m (kg)
(a)	(b)	(c)	(d)	(e)	(f)
1	8	5.3	4.2	5	3
2	9	6.1	5.4	6.5	3.7
3	10	6.9	6.5	8	4.6
4	12	10.4	9.5	11.6	6.5
5	14	13.8	12.9	15.6	9
6	16	19	16.8	20.4	11.6
7	18	22.2	21.1	26	15
8	20	27.5	26	32	18
9	22	32.6	31.7	38	22.3
10	24	39.4	37.6	46.1	26

Ser	Cordage Size (mm)	Natural Fibre	Nylon	Polyester	Polypropylene
		Wt per 100m (kg)	Wt per 100m (kg)	Wt per 100m (kg)	Wt per 100m (kg)
(a)	(b)	(c)	(d)	(e)	(f)
11	28	53.1	51.2	62.5	35.7
12	32	69.5	66.6	81.8	46.1
13	36	88.5	84.1	104	59.5
14	40	109	104	128	73
15	48	158	150	185	104

Fig 2-6-2 Weight of natural and synthetic cordage

### SAFE WORKING LOAD

2-6-4. **Cordage Breaking Strength.** The minimum breaking strength (MBS) of new cordage is listed in Fig 2-6-3. Cordage strength can be reduced up to 50% due to age. Knots, splices, sharp bends and kinks can further reduce the breaking strength by up to 30%. Saturation and the repeated wetting and drying of natural fibre cordage reduces the breaking strength still further. Natural fibre cordage gives a visible and audible warning of approaching failure, but the only sign of approaching failure with synthetic fibre cordage is a reduction in diameter as the strain is taken up.

#### MBS OF NATURAL AND SYNTHETIC CORDAGE

Ser	Cordage Size (mm)	Natural Fibre	Nylon	Polyester	Polypropylene
		MBS (kg)	MBS (kg)	MBS (kg)	MBS (kg)
(a)	(b)	(c)	(d)	(e)	(f)
1	8	480	1010	950	860
2	9	530	1270	1180	1070
3	10	630	1580	1440	1300
4	12	950	2250	2050	1860
5	14	1280	3170	2790	2550
6	16	1800	4050	3650	3040
7	18	2150	5070	4570	4050
8	20	2870	6350	5570	5070
9	22	3400	7610	6790	6090
10	24	4050	9150	8110	7100
11	28	5410	12230	10690	9630

Ser	Cordage Size (mm)	Natural Fibre	Nylon	Polyester	Polypropylene
		MBS (kg)	MBS (kg)	MBS (kg)	MBS (kg)
(a)	(b)	(c)	(d)	(e)	(f)
12	32	6920	15700	13650	12220
13	36	8620	19270	17210	15480
14	40	10490	25890	20780	18740
15	48	14770	33540	29440	26380

Note: MBS expressed in kg for simplicity. Multiply by  $9.81\text{m/s}^2$  to determine MBS in Newtons (N).

Fig 2-6-3 Minimum breaking strength of natural and synthetic cordage

2-6-5. **Safe Working Load.** The maximum SWL for all cordage strength calculations is based on the minimum breaking strength multiplied by age and routing reduction factors, and then divided by the safety factor. The MBS is detailed in Fig 2-6-3, the age and routing reduction factors in Fig 2-6-4 , and the safety factors in Fig 2-6-5.

#### CORDAGE AGE AND ROUTING REDUCTION FACTORS

Ser	Weakness	Reduction Factor
(a)	(b)	(c)
1	Age: New Used Old	1.0 0.9 0.5
2	Cordage Routing Sharp bends (such as rope passing around hooks) Knots Saturation (natural fibre only) Unequal distribution of stress (such as in the returns of a lashing)	0.7 0.7 0.7 0.8

Fig 2-6-4 Strength reduction factors for age and routing

#### SAFETY FACTORS GOVERNING CORDAGE USE

Ser	Usage	Safety Factor
(a)	(b)	(c)
1	Normal	6
2	Rough, including block and tackles systems	7
3	Hoisting and supporting personnel	10

Fig 2-6-5 Safety factors

## Rigging

2-6-6. **Calculating the SWL.** There are two methods for calculating the SWL; detailed and the field, or hasty method.

- a. **Detailed Calculation.** The SWL is calculated as follows:

$\text{SWL} = \text{MBS} \times \frac{\text{Age reduction factor}}{\text{(Largest)}} \times \frac{\text{routing reduction factor}}{\text{factor}} \div \text{Safety factor}$
<p>Note: SWL and MBS will be in same units of measure.</p>

Fig 2-6-6 Formula for determining SWL

- b. **Field / Hasty Calculation.** For field purposes, where the actual MBS is unknown, the formula in Fig 2-6-6 can be used to determine the minimum breaking strength with a factor of safety of six included.

MBS FIELD CALCULATIONS		
Ser	Cordage type	SWL (kg)
(a)	(b)	(c)
1	Natural Fibre	$d^2$
2	Polyethylene	$1.30d^2$
3	Polyester and polypropylene	$1.70d^2$
4	Polyamide	$2.00d^2$
5	Nylon	$2.25d^2$

where:  $d$  = cordage diameter (mm) and a safety factor of six is included.  
 NOTE: Only the weakest reduction factor for knots and sharp bends is used.

Fig 2-6-7 Field calculation method for determining MBS

### 2-6-7. Example Problems.

- a. What is the SWL of old 16 mm diameter manila cordage on a block and tackle? Solution:
- (1) MBS (Fig 2-6-3) = 1800 kg,
  - (2) Age reduction factor (Fig 2-6-4) = 0.5 (old),
  - (3) Safety factor (Fig 2-6-5) = 7 (rough usage), and
  - (4)  $\text{SWL} = 1800 \times 0.5 \div 7 = 128.5 \text{ kg.}$

- b. What size manila cordage is required to lift a 250 kg weight?  
Solution:

- (1)  $SWL = 250 \text{ kg}$ ,
- (2) Safety Factor (Fig 2-6-5) = 6 (normal),
- (3)  $SWL = MBS / \text{Safety Factor}$   
 $\hat{MBS} = SWL \times \text{Safety Factor}$   
 $MBS = 250 \times 6 = 1500 \text{ kg}$ , and
- (4) The smallest size manila cordage which can support a MBS of 1500 kg is 16 mm with a MBS of 1800 kg (Fig 2-6-3).

- c. Using the detailed calculation method, what is the SWL of saturated 32 mm polyester cordage with sharp bends? Solution:

- (1)  $MBS \text{ (Fig 2-6-3)} = 13650 \text{ kg}$ ,
- (2) Age Reduction Factor (Fig 2-6-4) = 0.9 (used),
- (3) Routing Reduction Factors (Fig 2-6-4) = 0.7 (sharp bends) or 0.7 (saturated),
- (4) Safety Factor (Fig 2-6-4) = 6 (normal usage), and
- (5)  $SWL = 13650 \times 0.9 \times 0.7 / 6 = 1433.25 \text{ kg}$ .

- d. Using the field calculation method, calculate the solution for the example in sub-paragraph c. Solution:

- (1)  $MBS \text{ (Fig 2-6-7)} = 1.7 (d^2)$ . The Safety Factor is included in this formula,
- (2) Age Reduction Factor (Fig 2-6-5) = 0.9 (used),
- (3) Usage Reduction Factor (Fig 2-6-5) = 0.7 (sharp bends) or 0.7 (saturated), and
- (4)  $SWL \text{ (Fig 2-6-7)} = 1.7 (32)^2 \times 0.9 \times 0.7 = 1096.70 \text{ kg}$ .

The field calculation method provides a lower safe working load.

**WORKING WITH CORDAGE BY HAND**

2-6-8. **Minimum Diameter.** Notwithstanding any calculations above, when cordage is worked by hand, for example, in tackles, its diameter shall not be less than 16 mm. Cordage less than 12 mm diameter is not to be used for any load carrying purpose.

## ANNEX A

## COMPARATIVE QUALITIES OF NATURAL AND SYNTHETIC CORDAGES

Ser	Fibre	Constitution	Description	Identification					Specific gravity
				Reaction to heat	Sensitive to	Resistant to	Dry	Wet	
(a)	(b)	(c)	(d)	(e)	(f)	(g)	(h)	(i)	(j)
1	Sisal	Agave Sisal and vegetable fibre natural.	A hard fibre, strong, light yellow to reddish in colour. Obtained from the leaves of Agave Sisalana in Java, Africa and Bahamas. Inferior to Manila in strength and water resistance.	Burn when fibre touches flame. Supports combustion. Short after-glow. Smells of burning paper. Leaves a soft grey ash, similar to cotton.	Mineral acids, weak or strong. Paints, detergents, chemical salts, fats, some oils, some solvents, weathering, sunlight, fungi, and moisture.	Volatile petroleum solvents, batching oils and alkalis generally.	Fibre 2.9% extension causes rupture. Rope 13% extension causes rupture.	Fibre 3.4% extension causes rupture. Rope 16% extension causes rupture.	1.50
2	Manila	Abaca, vegetable fibre, natural, 65% cellulose, 12% water, 22% pectin. Other wax and siliceous matter.	Strongest of all vegetable fibres. Obtained from a tree of the Banana family in the Philippine Islands. Fibre is up to 2.4 m long, light in weight, whitey-brown in colour, lustrous, very strong and durable.	Critical temperature is 150°C, after which fibre burns as flame. It supports combustion. Smells of burning paper and has an after-glow (smoulders).	Mineral acids, weak or strong. Paints, detergents, chemical salts, fats, some oils, some solvents, weathering, sunlight, fungi, and moisture.	Volatile petroleum solvents, batching oils and alkalis generally.	Fibre 2.8% extension causes rupture. Rope 13% extension causes rupture.	Fibre 3.2% extension causes rupture. Rope 15% extension causes rupture.	Approx 1.50
3	Nylon Type 66	Polyamide (Synthetic).	Continuous filament or staple. Resistant to abrasion and bacteria. Transparent, strong fibre of a circular cross-section.	Will not burn. Softens at 235°C. Melts at 250°C. Leaves hard beads and has a celery smell.	Phenols, strong acids, concentrated formic acid. Oxidization and yellowing above 150°C. Affected by prolonged exposure to sunlight.	Acetone, organic solvents, mineral and organic salts.	Very good recovery from stretch. Rope elongation at break about 40%. Good shock loading properties.	Highest of all textile fibres. Loses between 10% and 20% of dry strength when wet.	1.14
4	Polyester	Polyester (Synthetic).	Continuous filament staple. Very resilient and flexible. Resistant to abrasion and bacteria.	Melts at 260°C, and leaves hard balls and has an aromatic smell. Has the highest melting point of the commonly used synthetic fibres in rope and cordage.	Decomposed by strong hot alkalis, eg. caustic soda, ammonia. It is attacked by hot concentrated sulphuric acid and also by some hot organic solvents.	Strong mineral or organic acids at room temperature. It has excellent resistance to most organic solvents at room temperature. Has the greatest resistance to sunlight of the most commonly used synthetic fibres.	Good from stretch while the recovery extension at break for rope is about 35%.	Almost as high as polyamide. Wet strength the same as high dry strength.	1.38



Ser	Fibre	Constitution	Description	Identification					Specific gravity
				Reaction to heat	Sensitive to	Resistant to	Dry	Wet	
(a)	(b)	(c)	(d)	(e)	(f)	(g)	(h)	(i)	(j)
5	Polypropylene	Isotactic Polypropylene	Continuous multifilament, mono filament, and fibre film.	Shrinks rapidly from flame. Curls and melts at about 165 <sup>o</sup> C.	Sodium Hypochlorite (bleaching agent). Some hot organic solvents. Very susceptible to sunlight but with suitable additives loss of strength is retarded.	Hot and cold acids and alkalis.	Good recovery from stretch and the elongation at break for film ropes is from 25% to 30%.	All forms of polypropylene have a high tenacity with multi-filament being slightly higher than the other forms.	0.91

Fig 2A1 Comparative Qualities of Natural and Synthetic cordages

**CHAPTER 3**  
**STEEL WIRE ROPE**  
**SECTION 1**  
**INTRODUCTION**

**GENERAL**

3-1-1. Steel Wire Rope (SWR) is less likely to stretch than cordage, but it is not as flexible and therefore more difficult to handle. SWR is very susceptible to permanent damage from sharp bends and kinks. It is used in the field:

- a. where the loads involved would require use of cordage larger than 76 mm in diameter;
- b. where stretch under load is undesirable; and
- c. where power winches are used.

**CONSTRUCTION**

3-1-2. The basic element of wire rope is the individual wire which is made of steel or iron in various sizes. The wires are laid together to form strands. The strands are laid together around a core to form the rope.

3-1-3. The individual wires are usually wound or laid together in a direction opposite to the lay of the strands. The strands are then wound about a central core which supports and maintains the position of strands during bending and load stresses. The core may be constructed of fibre rope, independent wire rope or wire strand. The fibre core can be either vegetable or synthetic fibre rope and is treated with a special lubricant which helps keep the wire rope lubricated internally.

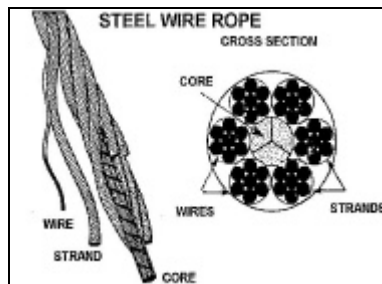

Fig 3-1-1 Construction of steel wire rope

## Rigging

3-1-4. Under tension, the wire rope contracts, forcing the lubricant from the core into the rope. After contracting, the fibre core acts as a cushion, absorbing stress and preventing the internal crushing of the individual wires. The limitations of fibre cores are reached when pressure, such as crushing in the drum, results in core collapse and distortion of the rope strand. Furthermore, if the rope is subjected to excessive heat, the vegetable or synthetic fibres may be damaged.

3-1-5. Under such severe conditions, independent wire rope cores are normally used. The independent wire core is actually a separate smaller wire rope and adds to the strength of the rope. A wire strand core consists of a single strand either of the same construction or sometimes more flexible than the main rope strands.

3-1-6. In some wire ropes, the wires and strands are preformed. Preforming is a method of setting the wires in the strands and strands in the rope, into the permanent helical or corkscrew form they will have in the completed rope. As a result, preformed wire rope does not contain internal stresses found in the non-preformed wire rope; therefore, it does not untwist as easily and is more flexible than non-preformed wire rope.

### LAY

3-1-7. Lay refers to the direction of the winding of the wires in the strands and the strands in the rope. Both may be wound in the same direction, or they may be wound in opposite directions. There are three types of rope lays: regular lay, Lang lay and reverse lay.

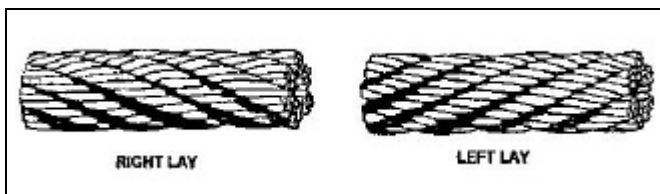

Fig 3-1-2 Right and left regular lays

3-1-8. **Regular Lay.** In regular lay, the strands and wires are wound in opposite directions. The most common lay in wire rope is the right regular lay (strands wound right, wires wound left). Left regular lay (strands wound left, wires wound right) is used where the untwisting rotation of the rope will counteract the unscrewing forces in the supported load as, for example, in drill rods and tubes for deep well drilling (Fig 3-1-2).

3-1-9. **Lang Lay.** In Lang lay, the strands and wires are wound in the same direction. Because of the greater length of exposed wires, the Lang lay assures longer abrasion resistance of the wires, less radial pressure on small diameter sheaves or drums by the ropes and less binding stresses in the wire than in regular lay wire rope. Disadvantages of the Lang lay are the tendency to kinking and unlaying or opening up of the strands, which makes it undesirable for use where grit, dust and moisture are present. The standard direction of Lang lay is right (strands and wires wound right, Fig 3-1-3), although it also comes in left lay (strands and wires wound left, Fig 3-1-4).

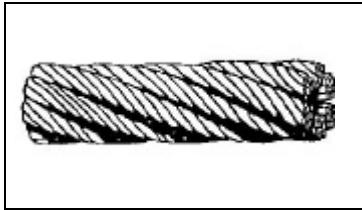

Fig 3-1-3 Right hand lay

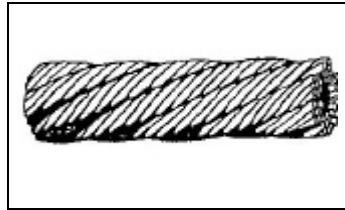

Fig 3-1-4 Left hand lay

3-1-10. **Reverse Lay.** In reverse lay, the wires of any strand are wound in the opposite direction of the wires in the adjacent strands. Reverse lay applies to ropes in which the strands are alternately regular and Lang lay. The use of reverse lay ropes is usually limited to certain types of conveyors. The standard direction of lay is right (strands wound right), as it is for both regular and Lang lay ropes.

## CLASSIFICATION

3-1-11. Wire rope is classified by the number of strands, number of wires per strand, strand construction and type of lay. Wire and strand combinations vary according to the purpose for which the rope is intended. The smaller and more numerous the wires, the more flexible the rope, but the less resistant to external abrasion.

3-1-12. Rope consisting of fewer larger wires is more resistant to external abrasion but is less flexible. The 6 x 37 (six strands, each of 37 wires) wire rope is the most flexible of the standard six-strand ropes. It is therefore useable with smaller sheaves and drums, such as on cranes. It is a very efficient rope because many inner strands are protected from abrasion by the outer strands.

## Rigging

3-1-13. The stiffest and strongest type of rope for general use is the 6 x 19 rope. This rope may be used over large diameter sheaves of larger diameter if the speed is kept to moderate levels. It is not suitable for rapid operation or for use over small sheaves because of its stiffness. Wire rope 6 x 7 is the least flexible of the standard rope constructions. It is well suited to withstand abrasive wear because of the large outer wires. See Fig 3B-1, Annex B, for SWR characteristics and applications for various strand/wire combinations.

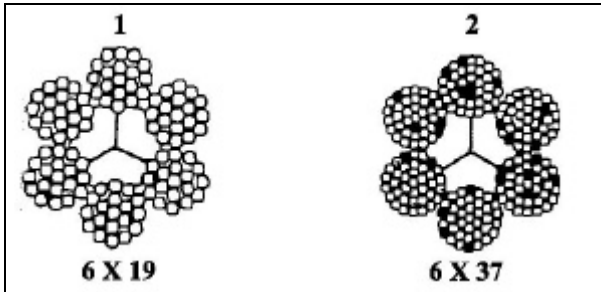

Fig 3-1-5 Arrangement of strands in wire rope

## SECTION 2

## CARE AND MAINTENANCE OF SWR

## COILING STEEL WIRE ROPE

3-2-1. **Storage.** Wire rope shall be coiled on a spool for storage and be properly tagged as to its size and length. It shall be stored in a dry place to reduce corrosion and be kept away from chemicals and fumes which might attack the metal. Before storage, wire rope will always be cleaned and lubricated. If the lubricant is applied properly and the wire is stored in a place protected from the weather, corrosion will be virtually eliminated. Rusting, corrosion of the wires, and deterioration of the fibre core significantly decrease the strength of the rope. The loss of strength caused by these effects is difficult to estimate.

3-2-2. **Coiling onto Reels.** Whenever possible, the rope shall be coiled on to a drum or reel as shown in Fig 3-2-1. Note that the direction of spooling depends on whether the lay is right or left. Each turn of the rope will be tight and close alongside the previous turn so that there is no gap into which the next layer of turns can drop. This is particularly important on winch drums where there is always a strain on the rope which may bite into turns underneath, thereby damaging or cutting them.

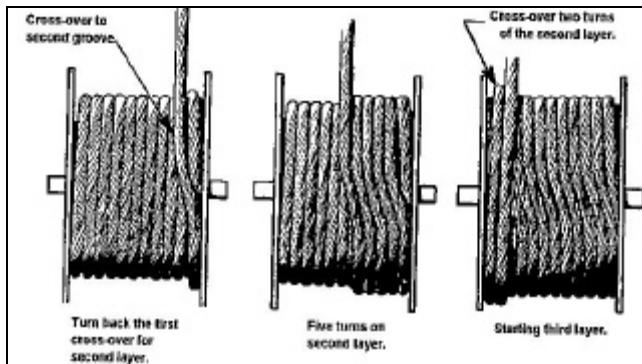

Fig 3-2-1 Coiling onto reels

3-2-3. **Coiling Around Pickets.** If a drum or reel is not available, the rope is coiled around pickets driven into the ground. For comparatively short lengths of light rope, set the pickets on the circumference of the circle and wind the rope around in a clockwise direction for right-hand lay rope

and in an counter-clockwise direction for left-hand lay, making sure that all kinks are taken out in the process. Larger ropes that are difficult to handle can be coiled around pickets but in the shape of a figure-of-eight which prevents the formation of kinks. In either case, when coiling is complete, the coil shall be secured at three or more points with light lashings.

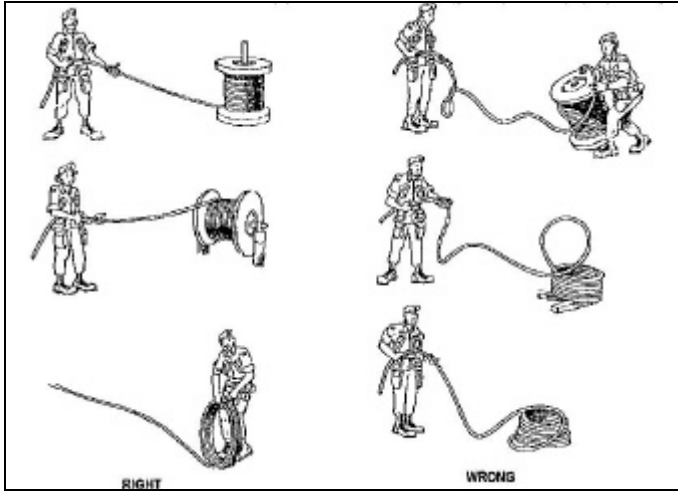

Fig 3-2-2 Uncoiling steel wire rope

3-2-4. **Uncoiling Steel Wire Rope.** When uncoiling SWR, it is important that no kinks are allowed to form, because once a kink is made, no amount of strain can take it out and the rope is unsafe to use. The best method of removing rope from a reel is to mount the reel on an axle on jacks or stands so that the rope is pulled off in the same manner that it was laid on the reel. An improvised turntable may also be employed to mount a reel or coil. This allows the rope to lead with perfect safety. If a turntable is not available, the coil of rope may be rolled along the ground. In no case shall the coil or reel be laid on the ground on its face and the rope taken over the end or from the centre of the coil, as kinks will result and the rope will be completely spoiled.

### CARE OF STEEL WIRE ROPE

3-2-5. **Whipping.** The ends of SWR shall always be whipped to prevent the wires untwisting. Before SWR is cut, it shall be whipped on either side of the intended cut using soft wire of 0.9 mm diameter, as shown in Fig 3-2-3. Three separate whippings shall be made on each side of the cut for rope over 20 mm diameter, and two whippings for rope under

20 mm diameter. Each whipping shall be 1.5 times as long as the rope diameter and spaced a distance apart equal to twice the diameter.

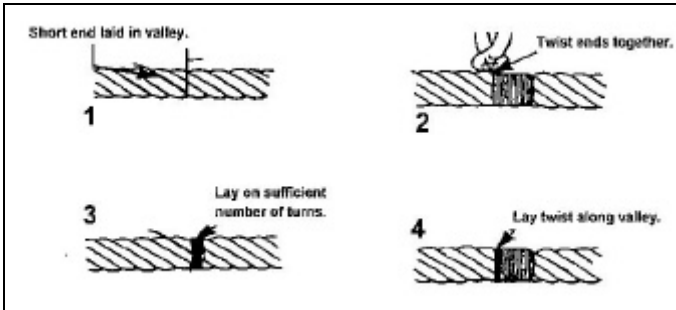

Fig 3-2-3 Whipping of steel wire ropes

3-2-6. **Kinks.** When loose wire rope is handled, small loops frequently form in the slack portion of the rope. If tension is applied to the rope while these loops are in position, they will not straighten, but will form sharp kinks, resulting in unlaying of the rope. All of these loops shall be straightened out of the rope before applying a load. After a kink has formed in wire rope it is impossible to remove it, and the strength of the rope is seriously damaged at that point. Such a kinked portion shall be cut out of the rope before it is used again.

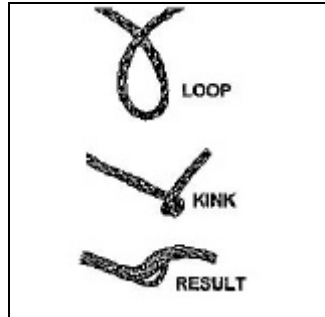

Fig 3-2-4 Kinking of wire rope

3-2-7. **Worming, Parcelling and Serving.** SWR will deteriorate rapidly if moisture is allowed to penetrate into the core and strands, or if the wires are subjected to chafing. Exposed rope can be protected by greasing, but hidden surfaces, for example, those in contact with the thimble, and strands that have been displaced in splicing, need special treatment. The three processes involved are described here and illustrated in Fig 3-2-5:

- a. **Worming.** Is the filling-up of any space between strands with spun yarn to render the surface smooth and round for parcelling and serving,



## Rigging

- b. **Parcelling.** Parcelling is achieved by wrapping a rope with pieces of greased canvas applied with the lay of the rope. This is then covered with gun tape in a similar manner to taping a hockey stick.
- c. **Serving.** Serving is long whipping. Serving may be done with spun yarn on cordage or SWR, but is usually done with steel wire on SWR. It is always applied against the lay of the rope. Kinks and twists shall be removed from the yarn or wire prior to its use. When the required length of serving has been put on, the end is put under the last two turns, pulled tight and cut off. All standing rigging or any other rope likely to be chaffed is always served.

"Worm and parcel with the lay,  
Serve the rope the other way."

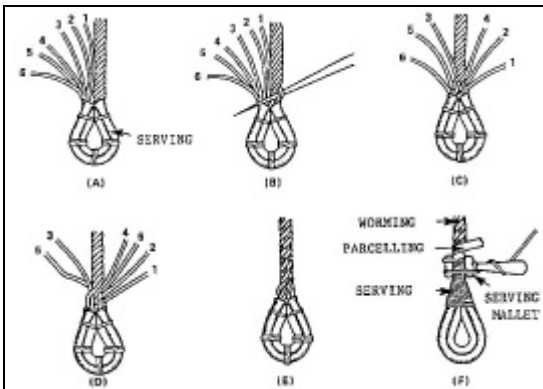

Fig 3-2-5 Worming, parcelling and serving

## INSPECTION

3-2-8. Wire ropes shall be inspected frequently. Frayed, kinked, worn, or corroded ropes will be replaced. The frequency of inspection is determined by the frequency of use of the rope. A rope that is used for one or two hours a week requires fewer inspections than rope which is used constantly. The weak points in the rope and the points where the greatest stress occurs will be inspected carefully.

3-2-9. Worn spots will appear as shiny flattened spots on the wires. If the outer wires have been reduced in diameter by one-fourth, the worn spot is unsafe.

3-2-10. It is important that broken wires be inspected regularly to determine whether it is a single broken wire or indeed several broken wires:

- a. if individual wires are broken next to one another, unequal load distribution will make the rope unsafe;
- b. when 4 % of the total number of wires comprising a type of wire rope are found to be broken in one strand (the distance in which one strand makes one complete turn around the rope), the rope is unsafe; and
- c. the rope is unsafe if three broken wires are found in one strand of 6 x 7 rope, six broken wires are found in one strand of 6 x 19 rope, or nine broken wires are found in one strand of 6 x 37 rope.

### **COMMON CAUSES OF SWR FAILURES**

3-2-11. The most common reasons for SWR failing are:

- a. manufactured in the incorrect size, construction, or grade;
- b. allowed to drag over obstacles;
- c. not properly lubricated;
- d. operated over sheaves and drums of inadequate size;
- e. overwound or crosswound on drums;
- f. operated over sheaves and drums out of alignment;
- g. permitted to jump sheaves;
- h. subjected to moisture or acid fumes; and
- j. permitted to untwist or kink.

### SECTION 3

## FASTENINGS AND FITTINGS

### GENERAL

3-3-1. Most of the attachments used with wire ropes are designed to provide an eye on the end of the rope by which maximum strength can be obtained when the rope is connected with another rope, hook or ring. Any two of the ends can be joined together, either directly or with the aid of shackle or end fitting. These attachments for wire rope take the place of knots. There are however some applications for knots in SWR.

### TYPES OF KNOTS

3-3-2. **Hawser Bend.** For joining two wire ropes.



Fig 3-3-1 Hawser bend

3-3-3. **Two Half Hitches.** For joining the end of a rope to a ring or spar.

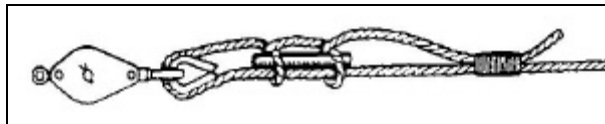

Fig 3-3-2 Two half hitches

3-3-4. **Carrick Bend.** For heavy loads and for joining large hawsers or heavy rope. It will not draw tight under a heavy load and is easily untied if the ends are seized to their own standing part.

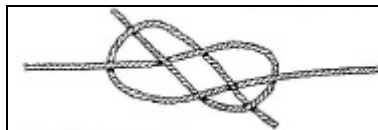

Fig 3-3-3 Carrick bend

### CLAMPS

3-3-5. Clamps are widely used for temporarily joining two lengths of rope of equal size, and for fastening the running end of a rope back to the standing part when forming an eye. Their use however, damages a rope and makes the part that has been crushed unsuitable for re-use. For this reason they shall be only used as permanent fittings, for example, in guys or stays. Although it will not be possible to conform to this practice in

field training or in many cases on operations, this requirement is to be observed in all other situations unless the part of the rope that has been crushed is cut off.

3-3-6. Clamps are available for all sizes of rope and if correctly used, will form an eye or joint capable of developing 80 percent of the breaking strain of the rope, that is, they result in a 20 percent loss in strength. Fig 3-3-6 details the number and spacing of clamps to be used on standard diameter ropes. If the table is not available during operations the following rules shall apply:

- a. ropes up to 18 mm in diameter are fastened by three clamps;
- b. ropes over 18 mm in diameter are fastened by four or more grips;
- c. the spacing between grips are at least six times the diameter of the rope;
- d. the clamps shall always be fixed with the bridge on the standing part of the rope (Fig 3-3-5); and
- e. only the correct sized clamps shall be used. Clamps have the size of the rope they are designed for stamped on their fittings.

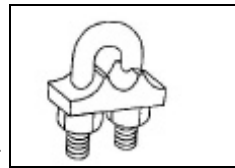

Fig 3-3-4 Bulldog grip clamp

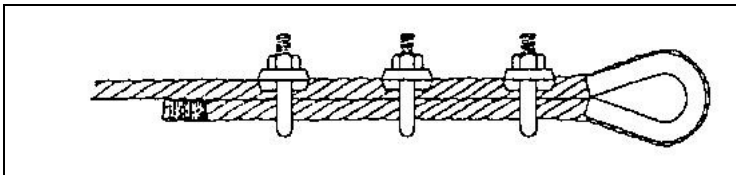

Fig 3-3-5 Eye on SWR formed with bulldog grip clamps

REQUIRED NUMBER OF FITTINGS

Ser	SWR Diameter (mm)	Number of Clamps
(a)	(b)	(c)
1	10 - 19	3
2	20 - 23	4
3	24 - 26	5

Ser	SWR Diameter (mm)	Number of Clamps
(a)	(b)	(c)
4	27 - 31	6
5	32 - 35	7

Fig 3-3-6 Required Number of Fittings

**STRENGTH FACTORS OF VARIOUS FITTINGS**

Ser	Fitting	Percentage of Full Strength of Rope
(a)	(b)	(c)
1	Bulldog grip clamps	80
2	Double-throated clamp	90
3	Single base clamp	80
4	Double base clamp	95

Fig 3-3-7 Strength Factors of Various Fittings

3-3-7. A wire rope clamp can be used with or without a thimble to make an eye in wire rope. Ordinarily a clamp is used to make an eye with a thimble. It has about 80 - 90 % of the strength of the rope. The two end collars shall be tightened with wrenches to force the clamp to a good snug fit. This crushes the pieces of rope firmly against each other.

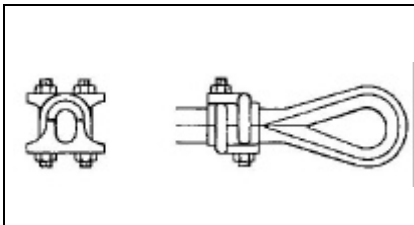

Fig 3-3-8 Double-throated clamp

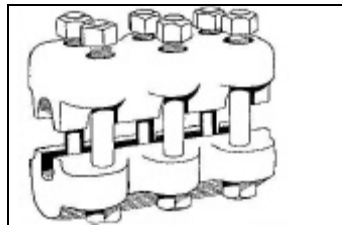

Fig 3-3-9 Double base clamp

**THIMBLES**

3-3-8. A thimble is a grooved metal ring, usually heart-shaped, used to prevent chafing or damage when a rope has to be fastened around a small diameter fitting such as a hook or shackle. A thimble is designated by the size of the largest rope for which the groove is designed. To install a thimble, first select one of proper size for the rope, then pass the rope around the thimble and secure the end to itself with a series of clamps. The first clamp shall be as close to the thimble as possible.

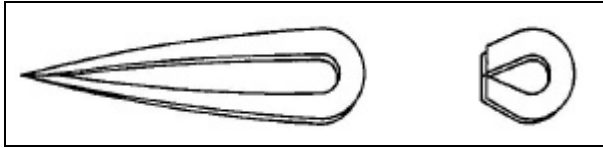

Fig 3-3-10 Thimbles

**SHACKLES**

3-3-9. Shackles are used to connect cordage and SWR with eye splices in the end, or chains, to rings and similar fittings. There are two types, the "Dee" and the "Bow". Both are inserted between the eye and the ring by unscrewing, removing, and replacing the pin. The pin is provided with an eye at the head in which a bar can be inserted for tightening up. Always use the manufactured shackle pin. Never replace it with a bolt.

**SAFE WORKING LOADS FOR SHACKLES**

Ser	Bow Diameter (mm)	Safe Working Load (t)				
		Bow Shackles		Dee Shackles		
		Large	Small	Small Ordinary	Narrow Jaw	Large Ordinary
(a)	(b)	(c)	(d)	(e)	(f)	(d)
1	9.5	0.35	0.4	0.5	0.5	0.4
2	12	0.6	0.75	0.85	1	0.6
3	16	1	1.1	1.4	1.5	1.1
4	19	1.5	1.5	2	2.25	1.6
5	22	2	2.25	2.75	3	2.25
6	25	2.75	3	3.5	4	3
7	29			4.25	5	3.75
8	32	4.25	4.5			
9	35			7	8	5.5
10	41			10	10.5	7.5

Fig 3-3-11 Safe Working Loads for Shackles

**HOOKS**

3-3-10. There is such a variety of hooks available for hoisting and rigging operations that it is impossible to deal with all of them in detail. There are, however, several considerations that apply to all hooks and

## Rigging

Observance of them will improve the safety standard. The following paragraphs will cover the safe working load for the most commonly used hooks in a hoisting or rigging operation.

3-3-11. Prior to using a hook, inspect it for faults. The most common hook inspection areas and faults are shown here.

3-3-12. The effects of eccentric loads on the hook's capacity are detailed in Fig 3-3-13.

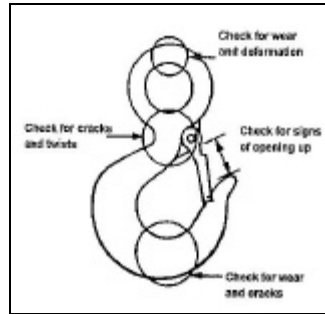

Fig 3-3-12 Hook inspection areas

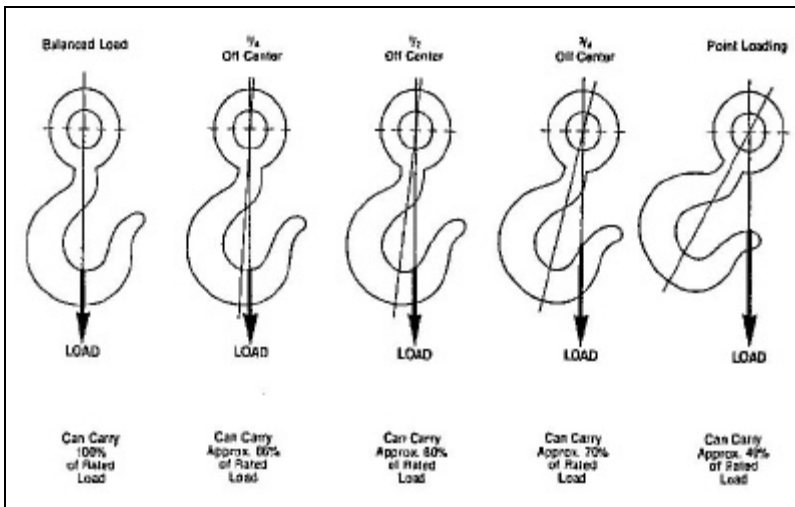

Fig 3-3-13 Effect of eccentric loads on hook capacity

3-3-13. The figures in Annex A to this chapter provide an indication of what load can be carried by a hook based on its throat opening. Refer to the manufacturers' ratings for specific values of specific hooks.

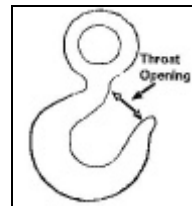

Fig 3-3-14 Throat opening

## SECTION 4

## SAFE WORKING LOAD OF SWR

## SWR SIZE, WEIGHT AND STRENGTH

3-4-1. **Size And Weight.** SWR is measured by its largest diameter, as shown in Fig 3-4-1. Its weight varies with its size and construction.

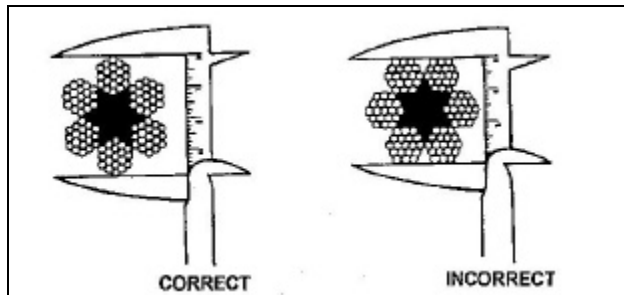

Fig 3-4-1 Measuring SWR

3-4-2. **Elasticity.** SWR exhibits both inelastic and elastic stretch. The initial stretch under load is inelastic and permanent.

3-4-3. **Breaking Strength.** The breaking strength of SWR is dependent on the wire grade, the size of the SWR, and its configuration. The following table is a planning guide to weight and MBS for SWR.

WEIGHT AND MBS OF SWR

Ser	Rope Diameter		Weight (kg/m) (1)	Minimum Breaking Strength (kg) (2) (3)
	in	mm		
(a)	(b)	(c)	(d)	(e)
1	$\frac{1}{4}$	6.3	0.179	1950
2	$\frac{5}{16}$	7.9	0.268	2948
3	$\frac{3}{8}$	9.5	0.387	4082
4	$\frac{7}{16}$	11.1	0.536	5896
5	$\frac{1}{2}$	12.7	0.699	7710
6	$\frac{9}{16}$	14.3	0.893	9524
7	$\frac{5}{8}$	15.9	1.09	12244
8	$\frac{3}{4}$	19.0	1.58	20317
9	$\frac{7}{8}$	22.2	2.14	23582
10	1	25.4	2.80	30747



## Rigging

Ser	Rope Diameter		Weight (kg/m) (1)	Minimum Breaking Strength (kg) (2) (3)
	in	mm		
(a)	(b)	(c)	(d)	(e)
11	1 <sup>1</sup> / <sub>8</sub>	28.6	3.56	34829
12	1 <sup>1</sup> / <sub>4</sub>	31.7	4.37	38275
13	1 <sup>3</sup> / <sub>8</sub>	34.9	5.30	41903
14	1 <sup>1</sup> / <sub>2</sub>	38.1	6.31	47345
15	1 <sup>5</sup> / <sub>8</sub>	41.3	6.92	53513
16	1 <sup>3</sup> / <sub>4</sub>	44.4	8.02	58955
17	1 <sup>7</sup> / <sub>8</sub>	47.6	9.21	63490
18	2	50.8	10.48	69386
19	2 <sup>1</sup> / <sub>8</sub>	54.0	11.83	81630
20	2 <sup>1</sup> / <sub>4</sub>	57.1	13.26	94328
21	2 <sup>3</sup> / <sub>8</sub>	60.3	14.40	108840
22	2 <sup>1</sup> / <sub>2</sub>	63.5	16.37	123352

Notes: 1. Weights are based on heaviest cable.  
 2. Nominal Breaking Strengths are based on weakest cable.  
 3. Nominal Breaking Strengths expressed in suspended mass (kg).  
 Multiply by 9.81m/s<sup>2</sup> to calculate max force (N)

Fig 3-4-2 Planning Guide to Weight and MBS of SWR

3-4-4. The strength of SWR is affected by age, routing of the rope and by fittings.

### SWR AGE, ROUTING AND FITTINGS REDUCTION FACTORS

Ser	Weakness/Use	Reduction Factors
(a)	(b)	(c)
1	Age: New	1.0
2	Used	0.9
3	Old	0.5
4	Rope Routing: Sharp bends (ie, rope passing around hooks)	0.7
5	Unequal distribution of stress (ie, in the returns of a lashing)	0.6

Ser	Weakness/Use	Reduction Factors
(a)	(b)	(c)
	Fittings:	
6	Double-Throated Clamps	0.9
7	Bulldog Clamps	0.8
8	Eye Splice	0.85
9	Long Splice	0.7
10	Short Splice	0.95

Fig 3-4-3 Steel Wire Rope Reduction Factors

### SWR SAFE WORKING LOAD

3-4-5. **SWL.** The SWL calculation for SWR is similar to SWL for cordage. The exception is a fittings reductions factor. The SWL for SWR is calculated using the MBS (Fig 3-4-2) multiplied by age, rope routing and fittings reduction factors (Fig 3-4-3) and divided by the appropriate safety factor (Fig 3-4-5) . See Fig 3-4-4

	Age	Rope	Fittings	Safety
SWL = MBS	x Reduction	x Routing	x Factor	÷ Factor
	Factor	Factor		

Fig 3-4-4 Formula for Determining the SWL for SWR

### SWR SAFETY FACTORS

Ser	Application	Safety Factor
(a)	(b)	(c)
1	Fixed guys, suspension bridge ropes, slings and tackles.	4
2	Head ropes on derricks, sheers and gyns. Ropes used in power operated cranes, vehicles and equipment.	5
3	Winch ropes.	6
4	Ropes used for lifting personnel.	10

Fig 3-4-5 SWR Safety Factors

3-4-6. **Field / Hasty Calculation.** If MBS tables are not available, the formula shown in Fig 3-4-6 can be used. It incorporates a safety factor of six.

## Rigging

$SWL = 8d^2 (RF)$	Where: d = diameter (mm) RF = weakest reduction factor
-------------------	---

Fig 3-4-6 Field Formula for Safe Working Load

3-4-7. **Slings** Maximum SWL of SWR slings are shown in the tables at Annex A to Chapter 5 (Figures 5A-5 and 5A-6).

## ANNEX A

## SAFE WORKING LOAD OF HOOKS

## SWL OF EYE, SHANK AND SWIVEL HOOKS

Ser	Throat opening		Maximum SWL(kg)
	in	mm	
(a)	(b)	(c)	(d)
1	$\frac{5}{8}$	15.9	272
2	$\frac{11}{16}$	17.5	363
3	1	25.4	680
4	$1 \frac{1}{16}$	27.0	907
5	$1 \frac{1}{8}$	28.6	1134
6	$1 \frac{1}{4}$	31.7	1814
7	$1 \frac{3}{8}$	34.9	2041
8	$1 \frac{13}{32}$	35.7	2268
9	$1 \frac{1}{2}$	38.1	2495
10	$1 \frac{17}{32}$	38.9	2722
11	$1 \frac{11}{16}$	42.9	3084
12	$1 \frac{25}{32}$	45.2	3629
13	$1 \frac{7}{8}$	47.6	3810
14	$1 \frac{15}{16}$	49.2	4534
15	$2 \frac{1}{16}$	52.4	4717
16	$2 \frac{1}{8}$	54.0	4990
17	$2 \frac{1}{4}$	57.1	5669
18	$2 \frac{5}{16}$	58.7	5897
19	$2 \frac{1}{2}$	63.5	7257
20	$2 \frac{9}{16}$	65.1	8165
21	3	76.2	8709
22	$3 \frac{1}{16}$	77.8	9072
23	$3 \frac{3}{8}$	85.7	10886
24	$3 \frac{7}{16}$	87.3	11793
25	4	101.6	15150

Fig 3A-1 Safe working loads of eye, shank, and swivel hooks

SWL OF CHAIN SLIP HOOKS

Ser	Throat Opening		Chain Size		Maximum SWL (kg)
	in	mm	in	mm	
(a)	(b)	(c)	(d)	(e)	(f)
1	1 <sup>1</sup> / <sub>16</sub>	26.9	<sup>1</sup> / <sub>4</sub>	6.3	1247
2	1 <sup>3</sup> / <sub>32</sub>	27.7	<sup>5</sup> / <sub>16</sub>	7.9	1950
3	1 <sup>5</sup> / <sub>16</sub>	33.3	<sup>3</sup> / <sub>8</sub>	9.5	2381
4	1 <sup>9</sup> / <sub>16</sub>	39.6	<sup>7</sup> / <sub>16</sub>	11.1	3175
5	1 <sup>11</sup> / <sub>16</sub>	42.9	<sup>1</sup> / <sub>2</sub>	12.7	4082
6	2	50.8	<sup>5</sup> / <sub>8</sub>	15.9	6123
7	2 <sup>1</sup> / <sub>8</sub>	54	<sup>3</sup> / <sub>4</sub>	19	8732
8	2 <sup>3</sup> / <sub>4</sub>	69.8	<sup>7</sup> / <sub>8</sub>	22.2	11793
9	3	76.2	1	25.4	15422

Fig 3A-2 Safe working loads of chain slip hooks

CHAIN GRAB HOOK CHARACTERISTICS

Ser	Throat Opening		Chain Size		Maximum SWL (kg)
	in	mm	in	mm	
(a)	(b)	(c)	(d)	(e)	(f)
1	<sup>11</sup> / <sub>32</sub>	8.7	<sup>1</sup> / <sub>4</sub>	6.3	1247
2	<sup>7</sup> / <sub>16</sub>	11.1	<sup>5</sup> / <sub>16</sub>	7.9	1950
3	<sup>1</sup> / <sub>2</sub>	12.7	<sup>3</sup> / <sub>8</sub>	9.5	2381
4	<sup>9</sup> / <sub>16</sub>	14.3	<sup>7</sup> / <sub>16</sub>	11.1	3175
5	<sup>21</sup> / <sub>32</sub>	16.7	<sup>1</sup> / <sub>2</sub>	12.7	4082
6	<sup>25</sup> / <sub>32</sub>	19.8	<sup>5</sup> / <sub>8</sub>	15.9	6124
7	1 <sup>5</sup> / <sub>16</sub>	33.8	<sup>3</sup> / <sub>4</sub>	19.0	8732
8	1 <sup>1</sup> / <sub>16</sub>	26.9	<sup>7</sup> / <sub>8</sub>	22.2	11793
9	1 <sup>3</sup> / <sub>16</sub>	30.1	1	25.4	15422

Fig 3A-3 Characteristics of chain grab hooks

## SLIDING CHOKER HOOKS CHARACTERISTICS

Ser	Throat Opening		Rope Size (mm)	MSW Load (kg)
	in	Mm		
(a)	(b)	(c)	(d)	(e)
1	$\frac{1}{2}$	12.7	6.3 - 7.9	680
2	$\frac{5}{8}$	15.9	9.5	1179
3	$\frac{7}{8}$	22.2	12.7	1542
4	$1 \frac{1}{8}$	28.6	15.9	2313
5	$1 \frac{1}{8}$	28.6	19.0	3629
6	$1 \frac{7}{16}$	36.5	22.2 - 25.4	6804
7	$1 \frac{3}{4}$	44.4	28.6 - 31.7	10433
8	$2 \frac{3}{16}$	55.6	34.9 - 38.1	13608

Fig 3A-4 Characteristics of sliding choker hooks

**ANNEX B**

**SWR CHARACTERISTICS AND APPLICATIONS**

Ser	Classification	Identification	Application
(a)	(b)	(c)	(d)
1	6 x 7 Fibre core improved plow steel (IPS)		Galvanized sashcords requiring high breaking strength, aerial tramways (Lang Lay), marine ropes (galvanized), guy ropes, drilling lines (sand lines) and haulage ropes for mining.
2	6 x 19 Fibre core	6 strands laid around a fibre core, with each strand consisting of 15 to 26 wires.	Mining (slusher) ropes, logging, and rotary drilling lines. Has maximum wear resistance but reduced flexibility. Pumping unit lines. General engineering purposes, slings, ropes for construction and industry such as scrapers, drag lines and cranes.  Logging operations for chokers, mainlines, skidders, shovel ropes and tow lines.
3	6x19 Independent wire rope core (IWRC)		General engineering purposes, cranes, hoists, general cargo handling. Mining (slusher) ropes, mono cable tramways, traction ropes on bicable tramways. Slings. Logging - chokers, mainlines, shovel ropes.
4	6x37 Fibre core and IWRC	6 strands laid around a fibre core, with each strand consisting of 27 to 49 wires	

Ser	Classification	Identification	Application
(a)	(b)	(c)	(d)
5	8 x 19	8 strands laid around a fibre or wire rope core, with each strand consisting of 19 to 26 wires	Hoist lines for tower and climber cranes (spin-resistant IWRC) - Shop cranes and conveyors.  Traction grade elevator ropes. Recommended where reverse bends and small sheaves are deciding factors against the use of 18 x 7 or 19 x 7 non-rotating ropes.
6	Non rotating 18 x 7 fibre core	12 right lay strands over 6 left lay strands around a fibre core	Special hoisting ropes. Two layers greatly restricts rotation of the rope and spinning of the load. This type of rope may not prove advantageous for certain hoisting applications, as overloading, shock loading and small diameter sheaves are frequent causes of rope damage. Seizings on non-rotating ropes shall not be removed.
7	6x24 Fibre core galvanized plow steel	6 strands around a fibre core, with each strand consisting of 24 wires laid around a fibre centre.	Marine ropes, mooring lines (generally manufactured without pre-lubrication).

Fig 3B-1 Characteristics of SWR



## CHAPTER 4

### CHAINS

#### GENERAL

4-1. For general construction rigging, chain shall never be used when it is possible to use SWR. The failure of a single link of a chain can result in a serious accident, while SWR, because of its multi-strand construction, is more dependable. SWR provides reserve strength and an opportunity to observe a potential hazard; chains do not.

4-2. When SWR is fatigued from severe service, individual wires break one after the other over a relatively long period of time, and provide an opportunity to discover the failure. If severely overloaded, the wires and strands will break progressively over a period of several seconds and with considerable noise before complete failure occurs.

4-3. Chains, on the other hand, will usually stretch a bit under excessive loading, the links elongating and narrowing until they bind on each other, thus giving some visible warning. However, if the overloading is great enough, the chain will ultimately fail with less warning than SWR. If a weld is defective, it will break with no warning. Chains are also much less resistant than SWR to sudden or impact loads and can break with no warning under such conditions.

4-4. There are certain jobs, however, for which chain is better suited than SWR. Chains withstand rough handling, do not kink, are easily stored, have good flexibility and grip the load well. They are much more resistant to abrasion and corrosion than SWR. They are particularly well suited as slings for lifting rough loads such as heavy castings, which would quickly weaken or destroy SWR slings due to the sharp bends over the casting edges.

#### TYPES OF CHAINS

4-5. **Short Link Chain**  
Chain is termed short link when the length of a link is less than five times the diameter of the rod from



Fig 4-1 Short link chain

which it is made the links are normally oval-shaped and have a good strength to weight factor

4-6. **Pitched Short Link Chain.** In pitched short link chain, the link sides are made parallel to prevent stretch and each link is twisted through 90 degrees so that the chain will lay flat and roll smoothly over the sheave of a block.

4-7. **Long Link Chain.** Chain is termed long link when the length of a link is more than five times the diameter of the rod from which it is made. Long link chain has more elasticity than short link chain, and has the disadvantage that the links can bend on sharp turns.

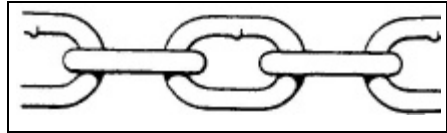

Fig 4-2 Long link chain

## CHAIN GRADES

4-8. It is very difficult to determine the grade of a chain by examination. However, all chain suitable for construction use, and in particular for hoisting, is marked by an identifying letter stamped on the links. The letter "A" designates heat-treated alloy steel which is the strongest chain commonly made. For the highest degree of safety, ensure that only chain stamped with the letter "A" is used for hoisting operations.

4-9. These alloy steel chains shall never be welded or exposed to high temperatures, as the heat will affect the temper, the chain will lose strength.

## STRENGTH

4-10 The table at Fig 4-3 gives the maximum SWL of new alloy steel chain when used as a single vertical sling. Maximum SWL of inclined slings, etc, are presented in Chapter 5.

4-11. Any change in the above factors, such as twisting or deterioration of the chain or its fittings by overload, use, rust, impact loading, or inclined (offset) loading will lessen the load that the chain will safely carry.

MAXIMUM SWL “A” TYPE ALLOY STEEL CHAIN

Chain Size Diameter		Capacity
in	mm	kg
1/4	6.3	1474
3/8	9.5	2994
1/2	12.7	5103
5/8	15.9	7484
3/4	19.0	10433
7/8	22.2	13041
1	25.4	17577
1 1/8	28.6	20185
1 1/4	31.7	26082
1 3/8	34.9	30391
1 1/2	38.1	36287
1 3/4	44.4	45359

Fig 4-3 SWL of Chain

4-12. Alloy steel chain can be used in environments up to 500°C without reducing the SWL. At temperatures above this level, the load limit decreases.

**INSPECTION**

4-13. All regularly used chains shall be thoroughly inspected on a link-by-link basis at least once a month and immediately prior to use by a competent inspector. Under no circumstances shall a chain be used for hoisting purposes, unless it has been closely examined for defects or wear.

4-14. Whenever a chain is subjected to shock or impact loads it will be immediately inspected before being put back into service. It is recommended that every chain carry a small metal identification tag bearing a serial number and its safe working load.

4-15. When inspecting chain, remember to give every link a close examination; one bad link is all that is needed to produce a catastrophic failure. The following guidelines will assist in conducting the inspection:

- a. clean the chain thoroughly in a solvent solution;
- b. lay it out on a clean surface or hang it in a well lighted area. Use a magnifying glass to aid in the inspection;

- c. look for elongated or stretched links. When the links are severely stretched they tend to close up so that in some cases stretch may be indicated by links that bind or a chain that won't hang perfectly straight. Elongation is determined by measuring all new chains in sections of up to one metre with a caliper and re-measuring them during the inspection. If the inspection reveals a stretch of more than 3%, take the chain out of service;
- d. look for bent, twisted or damaged links that often occur when the sling is used to lift a load having unprotected sharp edges;

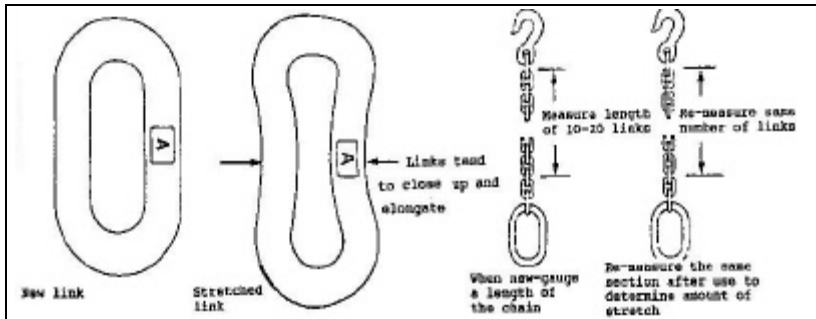

Fig 4-4 Inspecting for chain stretch

- e. look for cracked links. The presence of any crack, regardless of its size, means the chain is unsafe and is to be removed from service. Where a crack is suspected, the link may be soaked in thin oil and then wiped dry. A coating of powdered chalk or other white material is applied to the surface and allowed to remain there for several hours. If a crack exists, the oil pocketed in it will be drawn out and discolour the white coating;
- f. look for gouges, chips, scores, or cuts in each link. If they are deep or large in area then the chain shall be removed from service. If the depth of these defects is such that the link size is reduced below that listed in the table for wear, then the chain is unsafe. In addition, watch for sharp nicks and cuts because cracks are usually initiated at or near them.
- g. look for small dents, peen marks and bright polished surfaces on the links. These usually indicate that the chain has been work-hardened or fatigued;

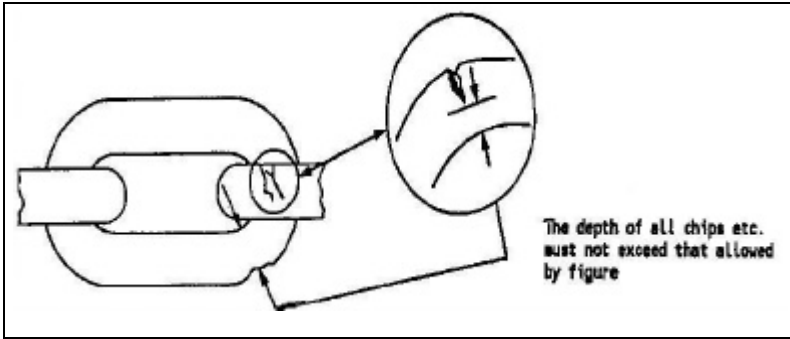

Fig 4-5 Inspecting chain links for gauges, chips and cuts

- h. look for lifted fins at welds. They are evidence of severe overloading and indicate that the whole chain shall be destroyed;

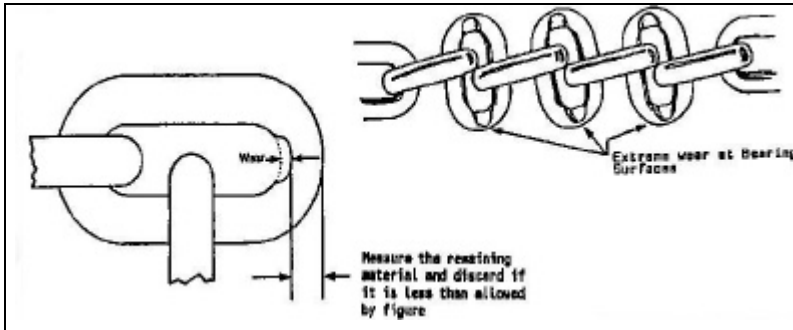

Fig 4-6 Inspect all chain links for wear at the bearing surface

- j. look for severe corrosion resulting in measurable material loss or severe pitting; and
- k. be particularly careful in determining link wear at the point where they bear on each other (Fig 4-6). A caliper is used for the measurement and the degree of wear at the worst section or the most badly worn link must be determined during the inspection. The table below gives the percentages by which the rated loads must be reduced to compensate for wear and the point at which the chain shall be removed from service.

## CORRECTION TABLE TO COMPENSATE FOR CHAIN WEAR

Ser	Original nominal chain stock diameter		Reduce rated capacity by the following % diameter at worn section is as follows				Remove from service when diameter is	
			5%		10%			
	in	mm	in	mm	in	mm	in	mm
(a)	(b)	(c)	(d)	(e)	(f)	(g)	(h)	(i)
1	$\frac{1}{4}$	6.350	0.244	6.198	0.237	6.020	0.233	5.918
2	$\frac{3}{8}$	9.525	0.366	9.296	0.356	9.042	0.335	8.509
3	$\frac{1}{2}$	12.700	0.487	12.237	0.474	12.040	0.448	11.379
4	$\frac{5}{8}$	15.875	0.609	15.469	0.593	15.062	0.559	14.199
5	$\frac{3}{4}$	19.050	0.731	18.567	0.711	18.059	0.671	17.043
6	$\frac{7}{8}$	22.225	0.853	21.666	0.830	21.082	0.783	19.888
7	1	25.400	0.975	24.765	0.949	24.105	0.895	22.733
8	$1\frac{1}{8}$	28.575	1.100	27.940	1.070	27.178	1.010	25.654
9	$1\frac{1}{4}$	31.750	1.220	30.988	1.190	30.226	1.120	28.448
10	$1\frac{3}{8}$	34.929	1.340	34.036	1.310	33.274	1.230	31.242
11	$1\frac{1}{2}$	38.100	1.460	37.084	1.430	36.322	1.340	34.036
12	$1\frac{5}{8}$	41.275	1.590	40.386	1.540	39.116	1.450	36.830
13	$1\frac{3}{4}$	44.450	1.710	43.434	1.660	42.164	1.570	39.878
14	$1\frac{7}{8}$	47.625	1.830	46.482	1.780	45.212	1.680	42.672
15	2	50.800	1.950	49.530	1.900	48.260	1.790	45.466

Fig 4-7 Table of compensation for chain wear

**CARE AND USE**

4-16. Use only alloy steel chains and never exceed their rated safe working loads. Know the weight of all loads to avoid accidental overloading.

4-17. Inspect chains regularly and take them out of service and destroy them when they are defective. Damaged or worn sections can sometimes be returned to the manufacturer for repair and reconditioning. Only specialists can repair alloy steel chain - do not attempt it yourself.

4-18. Avoid impact loading.

4-19. Store chains where they will not be damaged or corroded.

4-20. Make sure the chain has not been shortened by twisting or knotting or by nuts and bolts.

## Rigging

4-21. Use pads, when wrapping chain around sharp corners, to prevent damage to the links.

4-22. Make sure the chain does not have any repair links, mechanical coupling links, low carbon steel repair links, homemade links, or makeshift fasteners, used to splice broken lengths of alloy steel chain. They are much weaker than the original chain links.

4-23. Check the chain to ensure the links are not locked, stretched or without free movement. Stretching can be distinguished by small checks or cracks in the links, elongation of the links or a tendency for the links to bind on each other.

4-24. Make sure the chain links hang free. Never hammer a chain to straighten the links or to force the links into position.

4-25. Avoid crossing, twisting, kinking or knotting a chain.

4-26. Make sure the load is not carried on the tip of the chain hook.

4-27. Never re-weld alloy steel chain links. They are to be replaced by the manufacturer.

4-28 . Inspect each link regularly for wear, nicks, gouges, stretch, localized bending and shearing.

4-29 . Make sure the chain is of the correct size and grade for the load.

4-30 . Make sure all attachments and fittings are of a type, grade and size suitable for service with the chain used.

4-31 . Make sure that alloy steel chains are never annealed or heat treated. Their capacity will be completely destroyed if they are.

## CHAPTER 5

### SLINGS

#### GENERAL

5-1. Slings require special attention because they are almost always subjected to severe wear, abrasion, impact loading, crushing, kinking, and overloading. They also merit special attention because small changes in sling angle drastically reduces the load lifting capacity of the sling. The use of field fabricated slings is prohibited. When using slings exercise extreme caution because load weights are often unknown, circumstances are often less than ideal, and equipment may be less than perfect.

5-2. Sling splices shall never be bent around sharp corners. When lifting loads with sharp edges, slings shall be protected with packing. Failure to provide packing at corners and sharp edges will permit cuts and undue wear to develop in slings. Slings shall not be dragged beneath loads. Pulling slings from under loads will result in abrasion and kinking. Dropping loads on slings or running equipment over them will cause crushing. Sudden starts and stops when lifting loads will increase the stresses in slings and improper storage will also result in deterioration. All slings shall be maintained in the same manner as the material from which they are made.

#### SAFETY

- 5-3. The following sling safety points shall be observed:
- a. personnel shall not walk under a slung load;
  - b. the operator of a crane, HIAB or other lifting vehicle shall be provided with a competent ground guide who shall be positioned to see the entire operation area;
  - c. the standard ground guide-to-operator hand signals shall be utilized;
  - d. helmets and work gloves shall, be worn by all sling crews;
  - e. tag lines shall be considered for every load. A plan shall be developed so the entire crew knows what is expected of them in any situation. This will prevent accidents;



## Rigging

- f. never ride a load; and
- g. no sling shall be used unless it is properly rated and tagged.

5-4. Slings are to be inspected frequently and a tag showing the date of inspection will be attached to the sling. Slings are to be discarded if:

- a. any of the fibres or wires are cut, broken, or noticeably worn;
- b. any section has a reduced diameter;
- c. any mould, rot, or rust is detected in the sling's interior; or
- d. there are any doubts at all regarding their serviceability.

5-5. Because of the severe service expected of slings, errors in determining load weight, and the effect of sling angle on the loading, all safe working loads will be based on a safety factor of at least five. The sling's working load shall be marked on the end fittings, expressed in metric tonnes.

### SLING CONFIGURATIONS

5-6. The term "sling" includes a wide variety of configurations for all cordage, wire ropes, chains, and webs. The most commonly used types in construction rigging will be considered here because improper application can affect the safety of the lift.

5-7. **Single Vertical Hitch** is a method of supporting a load by a single vertical part or leg of the sling. The total weight of the load is carried by a single leg, the angle of the lift is 90° and the weight of the load can equal the maximum safe working load of the sling and fittings. The end fittings of the sling can vary but thimbles shall be used in the eyes. Also, the eye splices in wire ropes will be Mechanical-Flemish splices for best security. This sling configuration will not be used for lifting loose material, lengthy material or anything that will be difficult to balance. Use them only on items equipped with lifting eye bolts or

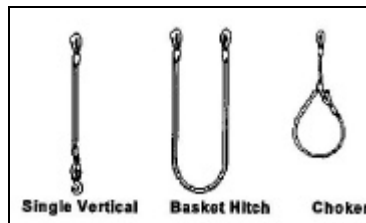

Fig 5-1 Single vertical, choker and basket hitch (vertical legs)

shackles such as concrete buckets. They provide absolutely no control over the load because they permit rotation.

5-8. **Bridle Hitch.** Two, three or four single hitches can be used together to form a bridle hitch for hoisting an object that has the necessary lifting lugs or attachments. They can be used with a wide assortment of end fittings. They provide excellent load stability when the load is distributed equally among the legs, if the hook is directly over the centre of gravity of the load and the load is raised level. In order to distribute the load equally it may be necessary to adjust the leg lengths with turnbuckles. The use of a bridle sling requires that the sling angles be carefully determined to ensure that the individual legs are not overloaded. Unless the load is flexible, it is wrong to assume that a three or four leg hitch will safely lift a load equal to the safe load on one leg multiplied by the number of legs because there is no way of knowing that each leg is carrying its share of the load. With slings having more than two legs and a rigid load, it is possible for two of the legs to take practically the full load while the other(s) only balance it.

5-9. **Single Basket Hitch** is a method of supporting a load by hooking one end of a sling to a hook, wrapping it around the load, and securing the other end to the hook. It cannot be used on any load that is difficult to balance because the load can tilt and slip out of the sling. On loads having inherent stabilizing characteristics the load on the sling will be automatically equalized with each leg supporting half the load. Ensure that the load does not turn or slide along the sling during a lift because both the load and sling will become damaged.

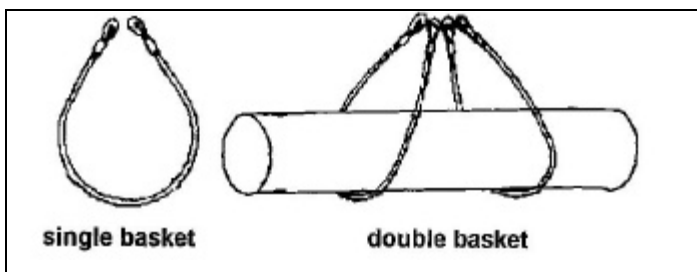

Fig 5-2 Single and Double Basket Hitches

5-10. **Double Basket Hitch** consists of two single basket hitches passed under the load. The legs of the hitches shall be kept far enough apart to provide balance but not so far apart that excessive angles are developed or a tendency is created for the legs to be pulled in toward the

centre. On smooth surfaces, both sides of the hitches shall be snubbed against a step or change of contour to prevent the rope from slipping as load is applied. The angle between the load and the sling shall be approximately  $60^\circ$  or greater to avoid slippage.

5-11. **Double Wrap Basket Hitch** is a basket hitch that is wrapped completely around the load rather than just supporting it as do the other basket hitches. The double wrap basket hitch can be used in pairs like the double basket hitch. This method is excellent for handling loose material, pipe, rods or smooth cylindrical loads because the rope or chain exerts a full  $360^\circ$  contact with the load and tends to draw it together.

5-12. **Single Choker Hitch** forms a noose in the rope that tightens as the load is lifted. It does not provide full  $360^\circ$  contact with the load, and because of this, it should not be used to lift loose bundles from which material can fall or loads that are difficult to balance. The single choker can also be doubled up to provide twice the capacity or to turn a load (not to be confused with double choker hitch). The double choker hitch is attached to the load in two places and the doubled up single choker hitch is only attached in one place. When it is necessary to turn a load, the choker is made by placing both eyes of the sling on top of the load with the eyes pointing in the direction opposite to the direction of turn. The centre of the sling is passed around the load, through both eyes and up to the hook. This hitch provides complete control over the load during the entire turning operation, and the load automatically equalizes between the two supporting legs of the sling. Because the load is turned into a tight sling, there is no movement between the load and the sling. If it is incorrectly made and the two eyes are placed on the crane hook - the supporting legs of the sling may not be equal in length and the load may be imposed on one leg only.

5-13. **Double Choker Hitch** consists of two single chokers attached to the load and spread to provide load stability. They, like the single choker, do not completely grip the load but because the load is less likely to tip they are better suited for handling loose bundles, pipes, rods, etc.

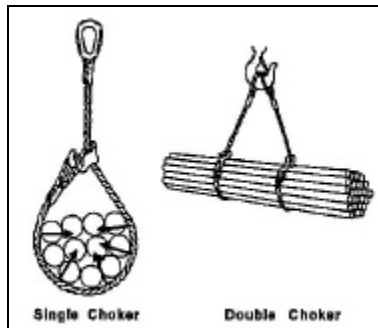

Fig 5-3 Choker hitches

5-14. **Double Wrap Choker Hitch** is one in which the rope or chain is wrapped completely around the load before being hooked into the vertical part of the sling. This hitch is in full contact with the load and tends to draw it tightly together. It can be used either singly on short, easily balanced loads or in pairs on longer loads.

5-15. **Endless Slings or Grommet Slings** are endless ropes that are made from one strand of a rope laid or twisted around itself on each successive loop. There is only one tuck in the entire circumference where the two ends enter the rope. These slings can be used in a number of configurations, as vertical hitches, basket hitches, choker hitches, and all combinations of these basic configurations. They are very flexible but tend to wear and deteriorate more rapidly than the other slings because they are not normally equipped with fittings. Thus they are deformed when bent over hooks and bear against themselves at the bight.

5-16. **Braided Slings** are usually fabricated from six or eight small diameter ropes braided together to form a single rope that provides a large bearing surface and tremendous strength and flexibility in all directions. They are very easy to handle and almost impossible to kink. The braided sling can be used in all the standard configurations and combinations but is especially useful for basket hitches where low bearing pressure is desirable or where the bend is extremely sharp.

## SLING ANGLES

5-17. The rated capacity of any sling depends on its size, its configuration, and the angles formed by the legs of the sling. A sling with two legs that is used to lift a 1000 kg object will have a 500 kg load in each leg when the sling angle is  $90^\circ$ . The load in each leg will increase as the angle is decreased. at  $30^\circ$  the load will be 1000 kg in each leg.

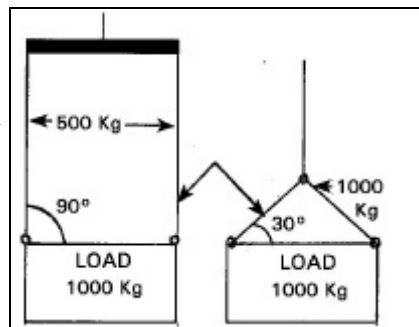

Fig 5-4 Load distribution in differing sling leg angles

5-18. If possible, keep the sling angles greater than 45°. Sling angles approaching 30° shall be considered extremely hazardous and avoided if at all possible.

### **SAFE WORKING LOADS**

5-19. The tables at Figures 5A-1 to 5A-6 at Annex A to this chapter contain Maximum SWL for various slings. These are composite tables suitable for field calculations

## ANNEX A

## SAFE WORKING LOAD OF SLINGS

## MANILA CORDAGE SLINGS WITH SPLICED EYES IN BOTH ENDS

Sér	Cordage Diameter		Maximum SWL (Safety Factor of 5) (kg) (3)					
			Single vertical hitch	Single choker hitch	Single basket hitch, vertical legs	2 Leg bridle & single basket hitches, legs inclined (1)(2)		
	in	mm				60°	45°	30°
(a)	(b)	(c)	(d)	(e)	(f)	(g)	(h)	(i)
1	$\frac{3}{16}$	4.8	45	35	91	77	64	45
2	$\frac{1}{4}$	6.3	54	41	109	95	77	54
3	$\frac{5}{16}$	7.9	91	68	181	159	127	91
4	$\frac{3}{8}$	9.5	123	91	245	213	172	123
5	$\frac{1}{2}$	12.7	240	181	481	417	340	240
6	$\frac{9}{16}$	14.3	308	227	617	535	436	308
7	$\frac{5}{8}$	15.9	399	299	798	690	563	399
8	$\frac{3}{4}$	19.0	489	363	980	848	694	489
9	$\frac{13}{16}$	20.6	590	445	1179	1021	835	590
10	$\frac{7}{8}$	22.2	699	522	1397	1211	989	699
11	1	25.4	817	612	1633	1406	1157	817
12	$1\frac{1}{16}$	27.0	953	717	1905	1633	1347	953
13	$1\frac{1}{8}$	28.6	1089	817	2177	1882	1542	1089
14	$1\frac{1}{4}$	31.7	1225	907	2449	2118	1724	1225
15	$1\frac{5}{16}$	33.3	1361	1021	2722	2359	1905	1361
16	$1\frac{1}{2}$	38.1	1678	1270	3357	2903	2381	1678
17	$1\frac{5}{8}$	41.3	2041	1542	4082	3538	2880	2041
18	$1\frac{3}{4}$	44.4	2404	1814	4808	4173	3402	2404
19	2	50.8	2812	2109	5625	4853	3992	2812
20	$2\frac{1}{8}$	54.0	3266	2449	6532	5670	4627	3266
21	$2\frac{1}{4}$	57.1	3720	2790	7439	6441	5262	3720
22	$2\frac{1}{2}$	63.5	4218	3175	8437	7303	5987	4218
23	$2\frac{5}{8}$	66.6	4717	3538	9435	8165	6668	4717

Notes: 1. If used with choker hitch, reduce above values by 25%.  
2. For double basket hitch, double above values.  
3. To calculate SWLs of endless or grommet slings, double all above values

Fig 5A1 SWL of manila cordage slings

## POLYPROPYLENE, POLYESTER AND NYLON CORDAGE SLINGS WITH SPLICED EYES IN BOTH ENDS

Ser	Cordage diameter		Maximum SWL (Safety Factor of 5) (kg) (3)					
			Single vertical hitch	Single choker hitch	Single basket hitch, vertical legs	2 Leg bridle & single basket hitches, legs inclined Notes (1) (2)		
	in.	m m				60E	45E	30E
(a)	(b)	(c)	(d)	(e)	(f)	(g)	(h)	(i)
1	$\frac{3}{16}$	4.8	68	50	136	118	95	68
2	$\frac{1}{4}$	6.3	113	86	227	195	159	113
3	$\frac{5}{16}$	7.9	181	136	363	318	254	181
4	$\frac{3}{8}$	9.5	227	170	454	390	318	227
5	$\frac{1}{2}$	12.7	377	281	753	635	544	377
6	$\frac{9}{16}$	14.3	435	327	871	771	612	435
7	$\frac{5}{8}$	15.9	590	442	1179	1021	817	590
8	$\frac{3}{4}$	19.0	771	578	1542	1315	1089	771
9	$\frac{13}{16}$	20.6	862	646	1724	1497	1225	862
10	$\frac{7}{8}$	22.2	998	748	1996	1724	1406	998
11	1	25.4	1315	987	2631	2268	1860	1315
12	$1\frac{1}{16}$	27.0	1361	1021	2722	2359	1905	1361
13	$1\frac{1}{8}$	28.6	1701	1270	3402	2948	2404	1701
14	$1\frac{1}{4}$	31.7	1905	1429	3810	3311	2676	1905
15	$1\frac{5}{16}$	33.3	1996	1497	3992	3447	2812	1996
16	$1\frac{1}{2}$	38.1	2722	2041	5080	4717	3856	2722
17	$1\frac{5}{8}$	41.3	3311	2495	6622	5715	4672	3311
18	$1\frac{3}{4}$	44.4	3946	2948	7893	6849	5579	3946
19	2	50.8	4717	3538	9435	8165	6668	4717
20	$2\frac{1}{8}$	54.0	5216	3901	11043	9027	7394	5216
21	$2\frac{1}{4}$	57.1	5987	4491	11975	10387	8482	5987
22	$2\frac{1}{2}$	63.5	6849	5126	13698	11884	9707	6849
23	$2\frac{5}{8}$	66.8	7711	5783	15422	13336	10886	7711

- Notes:
1. If used with choker hitch reduce above values by 25%.
  2. For double basket hitch double above values.
  3. To calculate SWLs of endless or grommet slings, double all above values.

Fig 5A2 SWL of synthetic fibre cordage slings

**NYLON AND DACRON WEB SLINGS**

Ser	Web width		Maximum SWL (Safety Factor of 5) (Eye & Eye, Triangle Fittings, Choker Fittings) (kg)					
			Single vertical hitch	Single choker hitch	Single basket hitch, vertical legs	2 Leg bridle & single basket hitches. Legs Inclined. See Notes (1) (2)		
	in	mm				60°	45°	30°
(a)	(b)	(c)	(d)	(e)	(f)	(g)	(h)	(i)
1	1	25.4	544	408	1089	943	771	544
2	2	50.8	1089	817	2177	1187	1542	1089
3	3	76.2	1633	1225	3266	2830	2313	1633
4	4	101.6	2177	1633	4355	3765	3084	2177
5	5	127.0	2722	2041	5443	4717	3856	2722
6	6	152.4	3266	2449	6532	5670	4627	3266
7	7	177.8	3810	2858	7620	6600	5398	3810
8	8	203.2	4355	3266	8709	7530	6169	4355
9	9	228.8	4899	3674	9798	8482	6940	4899
10	10	254.0	5443	4082	10886	9435	7711	5443
11	11	279.4	5987	4491	11975	10387	8460	5987
12	12	304.8	6532	4899	13064	11340	9253	6532

Notes: 1. If used with choker hitch reduce above values by 25%.  
2. For double basket hitch double above values.  
3. To calculate SWLs of endless or grommet slings, double all above values.

Fig 5A-3 Nylon and dacron web slings

**CHAIN (UNDER 2"/50mm) AND METAL (WIRE OR CHAIN) MESH SLINGS**

Ser	Type	Sling width		Maximum SWL (Safety factor of 5) (kg)					
				Single vertical hitch	Single choker hitch	Single basket hitch, vertical legs	2 Leg bridle & single basket hitches, legs inclined (1) (2)		
		in	mm				60°	45°	30°
(a)	(b)	(c)	(d)	(e)	(f)	(g)	(e)	(f)	(g)
1	Chains	1/4	6.3	1474	1107	2948	2540	2087	1474
		3/8	9.5	2994	2245	5987	5171	4218	2994
		1/2	12.7	5103	3810	10206	8845	7212	5103
		5/8	15.9	7484	5625	14969	12973	10569	7484
		3/4	19.0	10432	7802	20865	18053	14742	10433
		7/8	22.2	13041	9752	26082	22589	18416	13041
		1	25.4	17577	13154	35153	30436	24857	17577



Rigging

Ser	Type	Sling width		Maximum SWL (Safety factor of 5) (kg)					
				Single vertical hitch	Single choker hitch	Single basket hitch, vertical legs	2 Leg bridle & single basket hitches, legs inclined (1) (2)		
		in	mm				60°	45°	30°
(a)	(b)	(c)	(d)	(e)	(f)	(g)	(e)	(f)	(g)
		1 1/8	28.6	20185	15150	40369	34927	28576	20185
		1 1/4	31.7	26082	19505	52164	45133	36741	26082
		1 3/8	34.9	30391	22679	60781	52617	42865	30391
		1 1/2	38.1	36287	27216	72575	62596	51256	36287
		1 3/4	44.4	45359	34019	90719	78472	63957	45359
2	Heavy duty (10 guage mesh)	2	50.8	680	499	1361	1179	953	680
		3	76.2	1225	907	2449	2132	1724	1225
		4	101.6	1814	1361	3629	3130	2540	1814
		6	152.4	2722	2041	5443	4717	3856	2722
		8	203.2	3629	2722	7258	6260	5126	3629
		10	254.0	4536	3402	9072	7847	6396	4536
		12	304.8	5443	4082	10886	9435	7711	5443
3	Med duty (12 guage mesh)	2	50.8	612	454	1225	1043	862	612
		3	76.2	907	680	1814	1588	1270	907
		4	101.6	1225	907	2449	2132	1724	1225
		6	152.4	2041	1542	4082	3538	2903	2041
		8	203.2	2722	2041	5443	4717	3856	2722
		10	254.0	3402	2540	6804	5897	4808	3402
		12	304.8	4082	3062	8165	7076	5761	4082
4	Light duty (14 guage mesh)	2	50.8	408	318	817	726	590	408
		3	76.2	635	454	1270	1089	907	635
		4	101.6	907	680	1814	1588	1270	907
		6	152.4	1361	1021	2722	2359	1905	1361
		8	203.2	1814	1361	3629	3130	2586	1814
		10	254.0	2268	1701	4536	3901	3221	2268
		12	304.8	2722	2041	5443	4717	3856	2722

NOTES: 1. If used with choker hitch reduce above values by 25%.  
2. For double basket hitch, double above values.

Fig 5A-4 Maximum SWL of chain and metal slings

## WIRE ROPE SLINGS, 6 x 19 CLASSIFICATION GROUP

Ser	Rope diameter		Maximum SWL (kg) (3)					
			Single vertical hitch	Single choker hitch	Single basket hitch, vertical legs	2 Leg Bridle & Single Basket Hitches, Legs Inclined (1) (2)		
	in	mm				60°	45°	30°
(a)	(b)	(c)	(d)	(e)	(f)	(g)	(h)	(i)
1	$\frac{3}{16}$	4.7	272	204	544	476	386	272
2	$\frac{1}{4}$	6.3	499	374	998	862	703	499
3	$\frac{5}{16}$	7.9	748	567	1497	1293	1066	748
4	$\frac{3}{8}$	9.5	1089	817	2177	1882	1542	1089
5	$\frac{7}{16}$	11.1	1452	1089	2903	2517	2041	1452
6	$\frac{1}{2}$	12.7	1996	1497	3992	3447	2812	1996
7	$\frac{9}{16}$	14.2	2404	1814	4808	4173	3402	2404
8	$\frac{5}{8}$	15.8	2994	2245	5987	5171	4241	2994
9	$\frac{3}{4}$	19.0	4309	3221	8618	7484	6078	4309
10	$\frac{7}{8}$	22.2	5806	4355	11612	10070	8210	5806
11	1	25.4	7575	5670	15150	13109	10705	7575
12	$1\frac{1}{8}$	28.5	9616	7212	19232	16647	13608	9616
13	$1\frac{1}{4}$	31.75	11884	8936	23768	20593	16782	11884
14	$1\frac{3}{8}$	34.9	14696	11022	29393	25447	20775	14696
15	$1\frac{1}{2}$	38.1	17418	13064	34836	30164	24630	17418
16	$1\frac{5}{8}$	41.2	20502	15377	41005	35516	28985	20502
17	$1\frac{3}{4}$	44.4	23587	17690	47174	40823	33339	23587
18	$1\frac{7}{8}$	47.6	27578	20684	55157	47763	39009	27578
19	2	50.8	30663	22997	61326	53116	43363	30663
20	$2\frac{1}{4}$	57.1	38102	28576	76204	65998	53887	38102
21	$2\frac{1}{2}$	63.5	47174	35380	94347	81692	66678	47174
22	$2\frac{3}{4}$	69.8	55338	41504	110677	95844	78245	55338

NOTES: 1. If used with choker hitch reduce above values 25%.  
2. For double basket hitch, double above values.  
3. Values are for slings with eyes and thimbles in both ends, Flemish Spliced eyes, and mechanical sleeves.  
For eyes formed by cable clamps, reduce values by 20%.

Fig 5A-5 Maximum SWL for 6 x 19 wire rope slings

## WIRE ROPE SLINGS, 6 x 37 CLASSIFICATION GROUP

Ser	Rope Diameter		Maximum SWL (kg) (3)					
			Single vertical hitch	Single choker hitch	Single basket hitch, vertical legs	2 leg bridle & single basket hitches, legs inclined (1) (2)		
	in	mm				60°	45°	30°
1	1/4	6.3	454	340	907	794	635	454
2	5/16	7.9	725	544	1452	1247	1021	725
3	3/8	9.5	998	748	1996	1724	1406	998
4	7/16	11.1	1361	1021	2722	2359	1928	1361
5	1/2	12.7	1814	1361	3629	3130	2563	1814
6	9/16	14.3	2268	1701	4536	3924	3221	2268
7	5/8	15.9	2903	2177	5806	5035	4105	2903
8	3/4	19.0	4037	3039	8073	6985	5715	4037
9	7/8	22.2	5489	4128	10977	9525	7756	5489
10	1	25.4	7167	5398	14334	12428	10115	7167
11	1 1/8	27.0	8890	6668	17781	15377	12565	8890
12	1 1/4	28.6	11068	8301	22135	19187	15649	11068
13	1 3/8	31.7	13517	10160	27034	23405	19096	13517
14	1 1/2	38.1	16329	12247	32659	28304	23088	16329
15	1 5/8	41.3	19142	14379	38283	33158	27080	19142
16	1 3/4	44.4	21954	16465	43908	38011	31026	21954
17	1 7/8	47.6	25764	19323	51528	44634	36424	25764
18	2	50.8	28123	21092	56246	48716	39780	28123
19	2 1/4	57.1	36469	27352	72938	63185	51574	36469
20	2 1/2	63.5	44452	33339	88906	76975	62868	44452
21	2 3/4	69.8	53161	39871	106322	92079	75160	53161

NOTES: 1. If used with choker hitch reduce above values 25%.  
 2. For double basket hitch, double above values.  
 3. Values are for slings with eyes, and thimbles in both ends, Flemish Spliced eyes and mechanical sleeves. For eyes formed by cable clamps reduce values by 20%.

Fig 5A-6 Maximum SWL for 6x 37 wire rope slings

## CHAPTER 6

### ANCHORAGES

#### GENERAL

6-1. The design and construction of anchorages is a common engineer problem. Anchorages are used in both wet and dry applications and in diverse engineer tasks. This chapter deals with only the most common land anchorages.

#### TYPES

6-2. The most common types of anchorages used in field engineering tasks are:

- a. existing natural or structural holdfasts;
- b. picket holdfasts (wooden and steel);
- c. surface holdfasts;
- d. buried holdfasts;
- e. straight-pull rock anchorages; and
- f. elevated cable anchorages.

#### EXISTING NATURAL OR STRUCTURAL HOLDFASTS

6-3. **Trees.** Trees are uncertain as holdfasts since their holding power depends on the nature of the soil and the depth of their root system. A single tree can be strengthened by tying it back to a picket holdfast or to another tree (Fig 6-1). Two trees conveniently placed can be used with a baulk between them to which the rope is attached (Fig 6-2). The attachment shall always be made as close to ground level as possible.

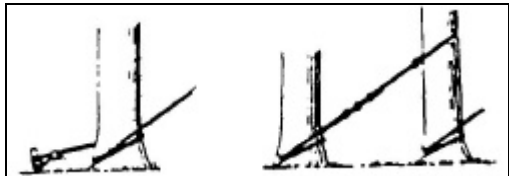

Fig 6-1 Tree and picket holdfast combination

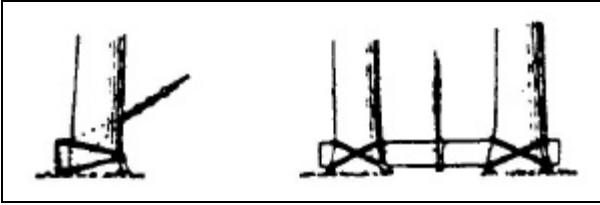

Fig 6-2 Tree baulk holdfast

6-4. The holding strength of a tree, when used as an anchor, is always a judgement call. The stoutness of a tree can be misleading if it is the only factor considered. A tree's ability to withstand stress is directly related to how well it is rooted. Some factors that indicate less than ideal rooting of a tree are:

- a. a naturally buttressed trunk such as a cypress tree;
- b. heavy roots visible on the surface;
- c. mountainous terrain or bedrock visible in the general area;
- d. distinct inclination of a stout tree;
- e. rainforest or jungle climate zones (generally shallow, high organic content and loose soil);
- f. trees developed away from any clearings or fields (generally shallower root system); and
- g. close proximity to water.

6-5. The time of year also plays a part in the suitability of a tree as an anchor. Frozen trees may catastrophically fail under a load that they would otherwise bear well. If sap is flowing, the tree will also be stronger than if it is not. Frozen ground can add to the ability of a tree to resist stress. These factors that may affect the ability of the tree to withstand stress shall be considered before committing lives or critical equipment to a natural anchor.

6-6. **Buildings.** Buildings make good holdfasts if the rope can be led through a door or window and secured to a baulk. The stress will be distributed over the walls by placing substantial planks between the baulk and the walls.

## WOODEN PICKET HOLDFASTS

6-7. The field engineer may be required to construct improvised wooden pickets. When doing so the following points shall be considered:

- a. the pickets will be driven two-thirds of their length into the ground at right angles to the line of the pull;
- b. the lashings connecting the pickets shall be at right angles to the pickets and shall come from the head of the leading picket to ground level on the trailing picket. This arrangement fixes the distance that the pickets are separated. All slack in the lashings shall be taken up;
- c. if pickets are of different size, the strongest shall be nearest the load; and
- d. pickets shall be tested before use to determine their holding power.

6-8. Pickets shall always be withdrawn on the same line as they were driven in. Pickets can be withdrawn using the method illustrated here.

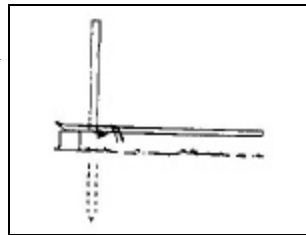

Fig 6-3 Method of withdrawing pickets

## STEEL PICKET HOLDFASTS

6-9. Steel picket holdfasts, or anchor earth holdfasts (AEHs), are very effective and quickly installed. The present steel AEH used in the CF is the British Ordnance Pattern Holdfast (OPH) (Fig 6-4). US inventory includes a system utilizing a chain as the holdfast base and similar pickets. The principles of use are identical.

6-10. **Anchor Earth Holdfasts (AEH).** Each anchorage set consists of a drilled steel bar, eight steel pickets, and a shackle at each end. The capacity of the shackle limits the AEH to a maximum load of 6 t. The pickets are 900 mm long and 20 mm in diameter. The picket head is

## Rigging

configured in such a way to prevent it being driven through the bar; and to facilitate withdrawal. One set will safely take a pull of 1000 kg in average ground and up to 2000 kg in good hard ground. The angle between the line of pull and the line of the bar shall not exceed 20°. Common configurations and their holding power are shown below.

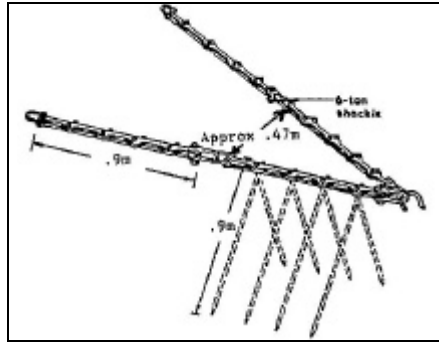

Fig 6-4 Anchor earth holdfast in four Vee configuration

### AEH MAXIMUM LOADS (kg)

Layout	Configuration	Ground	
		Good	Normal
	Single	2000	1000
	Two in Line	4000	2000
	Two Vee		
	Three Spread		3000
	Three in Line		
	Four Vee	6000	4000
	Six Spread		6000

Note: Max loads are expressed in kg for simplicity. To determine max load in Newtons (N) multiply kg by 9.8m/s<sup>2</sup>.

Fig 6-5 Anchor earth holdfast configurations

- 6-11. When laying out holdfasts, the following principles shall apply:
- a. the holdfast(s) shall be placed as near as possible along the line of pull;
  - b. three-legged holdfasts shall be arranged symmetrically on each side of the line of the pull. The angle between the outer legs shall be about 30 degrees; if it is much more, the strain will not be distributed equally between the pins; if it is much less, there will be a risk of over-stressing the natural resistance of the soil;
  - c. before driving the pins ensure that the bar is properly aligned on the ground. Drive the first pin at the head of the bar and the second at the tail to fix the position and then drive the intermediate pins; and
  - d. when fixing two holdfasts in tandem, all pins of the front holdfast are driven first. The rear bar is then shackled on, and held in tension and in the correct alignment while a pin is driven at the tail to position it.

## **SURFACE BAULK ANCHORAGES**

6-12. In surface baulk anchorages, the pull is taken by a timber baulk, log or rolled steel joist at ground level which is held in position by a series of 1:1 or 2:1 picket holdfasts (Fig 6-6). It is suitable for loads from 2 to 10 tonnes but the timber pickets must be load tested before use.

6-13. Owing to the difficulty in attaining an even distribution of the load between all the pickets, a 3:2:1 layout is never used for surface baulk anchorages. To allow for uneven load distribution, the calculations for safe load are based on the figure of 300 kg for each picket (front and rear). The resistance of the baulk to the imposed shear force will also be checked.

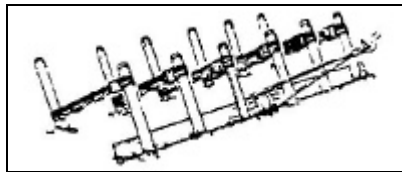

Fig 6-6 Surface baulk anchorage

6-14. When constructing a surface baulk anchorage the following points shall apply:



## Rigging

- a. there shall be the same number of holdfasts on either side of the main pull. The holdfasts shall be 450 mm apart and arranged symmetrically with respect to the main pull;
- b. the baulk shall bear as evenly as possible against all the pickets;
- c. the baulk shall rest on the ground and shall never be raised off the ground on packing. Sufficient soil will be removed to allow the rope to be passed round it;
- d. the rear edge of a square baulk shall be sunk in a shallow trench to obtain a fair bearing on the pickets; and
- e. a round turn will always be made around the baulk and, if the rope passes over sharp edges, it will be protected by packing or parcelling.

### BURIED BAULK ANCHORAGES

6-15. For pulls in excess of 10 tonnes, a buried anchorage is generally used. These are also called deadman anchorages. For short-term work, this usually takes the form of a single log, or group of logs buried horizontally in a trench. The strength of the anchorage depends on the ability of the ground to withstand the pressure transmitted by the pull. In soft ground, considerable advantage can be gained by the insertion of sheeting between the log and the side of the trench. An example of buried anchorages design is included at Annex A to this chapter.

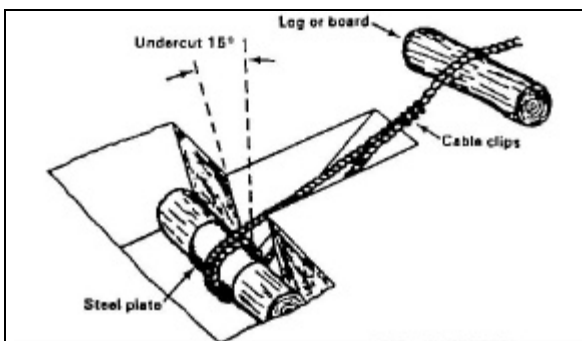

Fig 6-7 Buried baulk anchorage

6-16. **Dimensions.** The safe load that may be taken by a buried baulk also depends on the ability of the log itself to resist the imposed stresses.

The important dimensions are shown in Fig 6-8. The calculation of the allowable load of buried baulk anchorage is explained at paragraph 18.

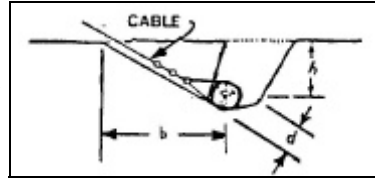

Fig 6-8 Buried anchorages

6-17. **Design Factors.** The factors below must be considered when selecting the log, baulk, or pipe for use as the buried anchorage: See Annex A of this chapter for a complete example in the design of a buried baulk anchorage.

- a. **Resistance to shear.** The log may fail in double shear. The shear force applied by the load (P) must not exceed the permissible shear force. Effective P (called 'Q' in the design example at Annex A) will be  $P/2$ ,  $P/4$  or  $P/6$  depending upon whether the load is connected at one, two or three points. Shear stress (S) is shown in the table at Fig 6-9:

SHEAR STRESS

Material and Shape	Formula
For a rectangular wood section	$S = 0.67 fs A$
For a circular wood section	$S = 0.75 fs A$
For a rectangular metal section	$S = fs A$
For a metal pipe	$S = 0.5 fs A$
where fs	= permissible shear stress,
S	= maximum force
fs for timber	= 0.69 Mpa
fs for steel	= 112.5 Mpa
A	= cross-sectional area

Fig 6-9 Shear Stress

- b. **Resistance to bending.** Under normal conditions, where the length of the baulk is at least five times the width of the cable trench, the baulk will fail in shear before bending, and its resistance in bending need not be considered. If there is any doubt, or other applications are necessary, bending moment can be determined from the table at Fig 6-10.

DETERMING THE MOMENT OF BEND

Material	Shape	Bending Strength
Timber and Steel	Square or Rectangular	$BS = [(b d^2) ? 6] Fc$
	Round	$BS = (D^3 ? 10) Fc$
Steel	Pipes	 $BS = [(D^4 - d^4) ? (10 D)] Fc$ D = outside diameter (m) d = inside diameter (m)
BS = Maximum permissible bending moment, Fc = Permissible bending stress, Fc Timber = 8.14 MPa, Fc Mild Steel = 165.0 MPa		

Fig 6-10 Bending Moment

6-18. **Resistance by the soil.** The following dimensions and factors shall be considered:

- a. **Effective area of the log (A).** The effective area of the log is more than its actual area owing to the distribution of the stress through the soil in a wedge formation and is influenced by the depth of the log. The formula to determine the effective area is found in the table below.

EFFECTIVE AREA OF A BURIED BAULK ANCHOR

Formula	Meaning of Symbols
$A = d (L + 1.6h - t)$	A = Effective area (m <sup>2</sup> ) d = Dia. of the log or dimension of flat surface in contact with the trench face (m) L = Length of the log (m) h = Mean depth of the log (m) t = Width of the cable trench (m)

Fig 6-11 Effective Area of a Buried Balk Anchor

- b. **Safe soil resistance (r).** Generally, the deeper the anchorage, the more holding power an anchor will provide. The baulk shall not be placed any closer than 0.3m to the ground water table. Use the table at Fig 6-12 to determine the appropriate depth.

SAFE SOIL RESISTANCE

Ser	Mean depth of face of anchorage below surface (m)	Allowable Load (N / m <sup>2</sup> of Anchor Face)				
		Slope of Cable				
		Vertical	1 : 1	1 : 2	1 : 3	1 : 4
(a)	(b)	(c)	(d)	(e)	(f)	(g)
1	0.3	3332	5292	7056	7644	8330
2	0.45	7154	11956	15288	17150	18620
3	0.6	13720	19600	27734	31066	33516
4	1	28714	45472	62132	69384	71736
5	1.25	50176	83300	104860	124460	129360
6	1.5	81340	133280	172186	191100	196000
7	1.8	114660	181300	244020	277340	287140
8	2	152880	244020	335160	383180	401800

Fig 6-12 Safe soil resistance (r) of earth face in a buried anchorage

- c. **Shape factor.** This depends upon the shape of the surface in contact with the soil face and will either be 1.0 for flat surfaces or 0.6 for round surfaces.

c. **Soil factor.** BURIED ANCHORAGE SOIL FACTORS

The soil factor for anchor design is shown here.

Soil Type	Factor
Compact Aggregate	1
Stiff Clay	0.9
Sandy Clay, Average Soil	0.7
Soft Clay, Loose Sand	0.5

Fig 6-13 Buried anchorage soil factors

- e. **Safe Pull.** The safe pull (P) is then given by the formula:

SAFE PULL

Formula	Meaning of Symbols
$P = A (r) \times \text{shape factor} \times \text{soil}$	P = Safe Pull (Ng) A = Effective Area (m <sup>2</sup> ) r = Safe Soil Resistance (N/m <sup>2</sup> )

Fig 6-14 Safe pull on buried anchor

## CONSTRUCTION

- 6-19. Buried anchorages are constructed as follows:
- a. The main trench is dug about 600 mm longer than the baulk, with the front face undercut ABOUT 15° and the axis of pull at right angles to the baulk;
  - b. The trench for the cable is dug from ground level to the bottom of the main trench at the correct slope and as narrow as possible. It may require revetting;
  - c. The log is lowered into the trench onto packing which must be sufficiently high above the bottom of the trench to permit the cable to be passed under the log;
  - d. A steel bearing plate shall be placed on the log where the cable is attached in order to prevent cutting into the baulk. With light cables, a turn can be taken round the log before it is lowered;
  - e. Wherever possible, the main trench shall be left open so that the anchorage can be monitored and maintained. However, an open trench on a work site poses a safety hazard; It shall be marked or temporarily covered with sheeting of some type. If the main trench is backfilled, it shall be compacted. When this is done, the anchorage can no longer be observed and any problems will manifest themselves without warning. If SWR is used as the main cable, the clips will be placed far enough from the baulk so that they can be maintained. The cable trench is always kept open to allow for inspection of the cable and its fastenings. If the main trench is backfilled, the part of the log to which the cable is attached shall be left uncovered so that the cable can be changed, adjusted or removed as necessary; and
  - f. The baulk shall be kept a minimum of 30 cm above the ground water level.

## STRAIGHT PULL ROCK ANCHORAGE

6-20. A straight pull rock anchorage (Fig 6-15) can only be used in sound hard rock. It shall not be used in rock that is badly cracked. If the surface of the rock is weathered, that portion shall be removed before the hole is drilled. The anchorage is based on the folding wedge principle and

consists of two tapered mild steel pins, one of which has a hole drilled in one end to take the load. The pins A and B are placed together and slipped into the drilled hole until the neck of B is about 50 mm from the collar of the hole. With B held stationary, A is hammered down thus clinching both A and B into the rock. Any pull on B will further wedge the two pins.

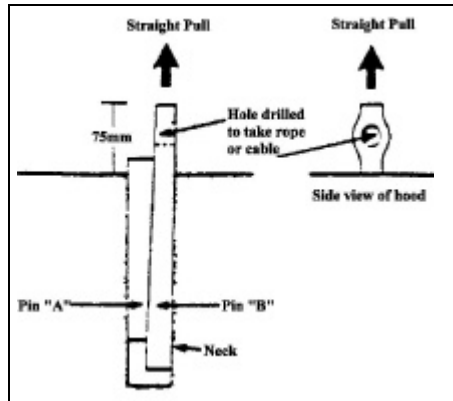

Fig 6-15 Straight pull rock anchorage

6-21. The hole shall be drilled at such an angle that the pull will be in a straight line with the axis of the pins. The strength of this type of anchorage depends on the strength of the rock as well as the size, shape and strength of the pins. There is no simple field formula to calculate strength, but in sound rock a pull of up to 12 tonnes can generally be applied. Wherever possible, this type of anchorage shall be test loaded.

6-22. To remove the anchorage, hammer B down to release the wedge and lift out the two pins together.

### **ELEVATED CABLE ANCHORAGE SYSTEM**

6-23. In bridging operations, particularly floating bridges and captive ferries, there is always a requirement for anchorages of some form. Fixed underwater anchorages are useful and may be suitable, but do have some drawbacks and limitations. Shorelines are often the most suitable system for anchoring floating bridges, but these shall not be at an angle less than 45°. This means that the shorelines will be very long and a method is required to support them. Bridging boats are a good method of holding floating bridges in place. They require refuelling, produce noise and exhaust fumes, can add to water pollution (which is a priority consideration

## Rigging

in peacetime), require constant attention by trained operators and crew, and place the boats, and their crews, in constant risk of attack. In situations where the nature of the bottom or shores or the resource and manpower requirements indicate that an alternate method of anchorage is necessary or desirable, the field engineer shall consider other anchorage systems, including the elevated cable anchorage system.

6-24. An elevated cable anchorage system is a cable strung across a gap to which bridle lines are attached. These lines are attached to the raft or bridge and transfer the load to the elevated cable. The elevated cable is usually supported by some form of tower though these can be very short if the banks are high enough. The ends of the suspended cable are then fixed to anchors on shore, the most common of these being the buried baulk. See Annex B of this chapter for a complete example on the design of an Elevated Cable Anchorage System.

## TOWERS

6-25. **Types.** There is no purpose designed tower for elevated cables presently in the Canadian inventory. Improvised towers can be constructed of field machines or, in the case of particularly high banks, very shallow cable supports can be used. There is also the possibility of using cable towers from other nations or even using existing buildings, trees or other structures which may be in the vicinity. The suitability of these alternatives is left to the determination of the engineer on site based on the principles discussed previously in this manual. The tower design will depend on a great many factors. If a multi-cable system is necessary, it does not follow that multiple towers are required. If a suitable saddle assembly can be fabricated, a single tower will suffice for up to three cables. The required specifications for any tower are easily determined.

6-26. **Separation.** The distance between towers is dictated by the water width. This may include the distances between high water marks or even the tops of the banks in some locations. An additional 10% is added for safety and 15 m is allowed for working room on each bank.

6-27. **Height.** The minimum effective tower height is determined by finding how high the cable must be at the towers in order to keep it out of the water at the point of maximum sag. This is found by multiplying the distance between the towers by the initial 2% sag and adding 1 m clearance allowance. Though 2% is not maximum sag, the variation between initial and final sags is minimal and is further reduced by the horizontal sag. The 1 m also ensures that no contact with the water will occur.

6-28. **Location.** To determine the distance between each tower and the bridge centreline, it is necessary to calculate the tower heights first. For banks less than 4.51 m high at the tower position, 15.25 m is added to the calculated tower height. For banks 4.51 m high or higher, 10.6 m is added to the tower height.

## CABLE

6-29. **Type.** Only SWR shall be used for the main cable as it is stronger, can withstand much more rigorous use and will not stretch as much as natural or synthetic fibre cordage. SWR is preferred for the bridle lines for the same reasons.

6-30. **Quantity.** Single cables are suitable for bridges up to 400m in length in low velocity current. Under some circumstances, such as tidal water or waters with strong winds from downstream, a downstream anchor cable may be required. If the current velocity or the tension applied to the cable is too great for any available cable, a multi-cable system may have to be used with alternating pontoons or bays attached to alternating cables.

6-31. **Floats.** The circumstances may make it impossible or undesirable to elevate a cable. Though not desirable, it is permissible to support the cable with suitable, anchored floats or rafts. Caution must be taken as the non-elevated cable will display all of the problems associated with and characteristics of a boom.

6-32. **Installation.** Any of the common methods of getting a cable across a gap may be a gap may be employed including walking it across an existing bridge. Towing the cable through the water shall be avoided if the bottom is unknown or could damage the cable.

6-33. **Sag.** Generally, tension decreases as sag increases. The cable should be tensioned until the initial unloaded vertical sag is 2%. This will provide a loaded vertical sag of about 5%. The amount that the cable is deflected downstream toward the bridge is called the horizontal sag and will vary as the velocity of the stream increases. Horizontal sag reduces vertical sag.

6-34. **Clearance.** Although it may be reduced without affecting the function of the system, 1m shall be planned as cable clearance above water. Local circumstances will dictate any variation in this allowance but it will be remembered that as the allowance increases the required tower height also increases and this may not be desirable.



## Rigging

6-35. **Backstay.** For the purposes of elevated cable anchorages, the part of the main cable that runs from the anchor to the tower is called the backstay. Depending on the requirements of the anchor used, the slope of the backstays can be as great as 1:1. As the incline increases the pull applied to the anchor also increases. Therefore it is best to have a shallow slope. If there is sufficient space available, a ratio of 1:4 is preferred.

CABLE SELECTION DATA

WWG up to (m)	Raft/Bridge Type	Minimum cable size (mm) at various current velocities											
		1.5 m/sec			2.1 m/sec			2.75 m/sec			3.3 m/sec		
(a)	(b)	X	Y	Z	X	Y	Z	X	Y	Z	X	Y	Z
61	Light	10	10	10	10	10	10	13	10	10	13	13	10
	Med.	13	10	10	16	13	13	20	16	13	23	20	16
122	Light	13	10	10	13	13	10	16	13	10	20	16	13
	Med.	16	13	13	20	16	13	26	23	16	32	26	20
183	Light	16	13	10	16	13	10	20	16	13	23	20	16
	Med.	20	16	13	26	20	16	29	26	20	39	32	23
244	Light	16	13	10	20	16	13	23	20	16	<b>D</b>	23	20
	Med.	23	20	16	29	23	20	35	29	23	<b>D</b>	39	29
305	Light	20	16	13	23	16	13	26	20	16	<b>D</b>	<b>D</b>	20
	Med.	26	23	20	32	26	23	39	35	26	<b>D</b>	<b>D</b>	32
366	Light	20	16	13	23	20	16	<b>D</b>	23	20	<b>D</b>	<b>D</b>	23
	Med.	29	23	20	35	29	23	<b>D</b>	39	29	<b>D</b>	<b>D</b>	35

Notes : 1. WWG - water line width of the wet gap  
 2. Number of cables - X = 1, Y = 2, and Z = 3 cables.  
 3. **D** = Too dangerous, do not use.

Fig 6-16 Cable Selection Data

6-36. **Capacity.** The working strength for the main cable is the pull that is safe to apply and still maintain an acceptable factor of safety. The Table at Fig 6-16 integrates an acceptable factor of safety and can be used to select both the size and quantity of cables required.

## BRIDGE / RAFT TYPES

6-37. Considering the vast array of potential gap crossing equipment in a multi-national conflict, the difference between a medium and a light bridge/raft can be quite ambiguous. The engineer on sight must decide whether or not the bridge will, or is likely to, induce a light load or a

strong load on the cable. This will be a function of not only the type of traffic on the bridge, tanks versus trucks, but also the current speed, potential debris in the water, the depth of the wet gap, and even the shape of the pontoons or bays. When in doubt, error on the side of caution and choose the heavier cable.

**ANCHORS**

6-38. **Types.** A variety of anchors may be used for the main cable. AEH systems or surface baulk anchorages may be suitable where the tension will not be great. However, suspended cables will usually require heavier anchorages. Pulls in excess of 10 t are to be expected and deadman anchors are generally the preferred system.

6-39. **Distance From Tower.** The location of the anchors in relationship to the towers is determined by the effective height and the backstay slope. If a tower of 10 m height is to support a cable with a planned backstay ratio of 1:3 the cable will intersect the ground 30m from the tower ( $10\text{ m} \times 3 = 30\text{ m}$ ). If the depth of the buried anchor is 1.5 m the cable will rise from it at the same ratio of 1:3 and will intersect the ground 4.5 m from the baulk. The combined distance, tower to anchorage, is 34.5m (Fig 6-17).

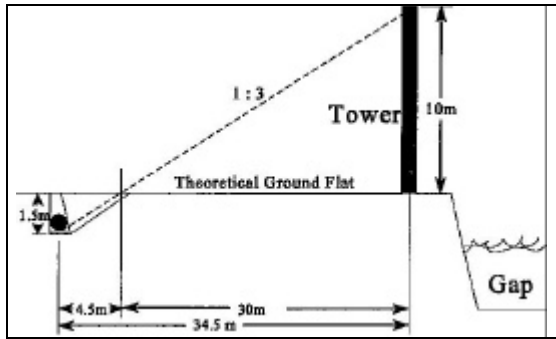

Fig 6-17 Slope ratio in level ground

6-40. These measurements assume that the ground is level between the tower and anchor. If the 34.5 m distance is measured from the tower on ground that rises, the slope ratio can alter

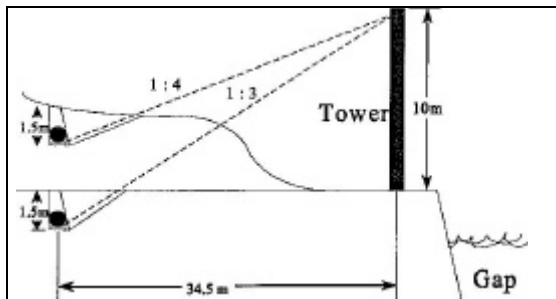

Fig 6-18 Slope ratio in rising ground

radically. Fig 6-18, on the previous page, shows that in this situation the slope ratio actually changes to 1:4.

6-41. When the same 34.5 m is measured over falling ground the ratio changes in the opposite direction. Fig 6-19 shows a change in slope ratio from 1:3 to 1:2. Since the buried anchorage is designed against the slope ratio, a radical change such as is depicted here could cause the failure of the anchorage with catastrophic results. To avoid this the designer will take into account the variation in ground elevation between the tower position and anchor position when locating a buried or other anchorage.

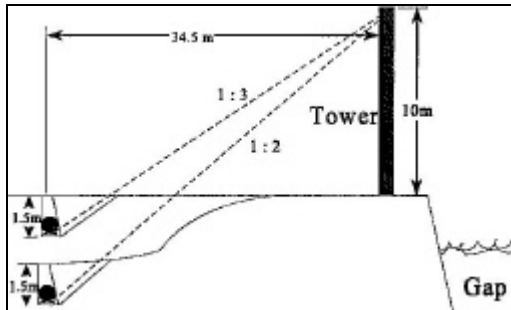

Fig 6-19 Slope ratio in falling ground

6-42. The critical factor in determining the position of a buried anchorage using a fixed slope ratio is the relative difference between the backstay's points of contact with the tower and the anchorage. In the example shown in Fig 6-20, the relative difference in height is calculated at 7.5m. At a ratio of 1:3 the location of the anchorage is then fixed at 22.5m.

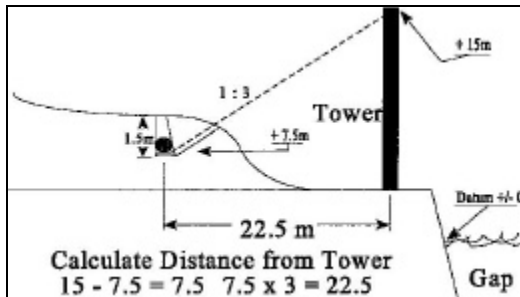

Fig 6-20 Corrected slope ratio

6-43. **Location Offset.** The offset of the anchors in relationship to the towers is determined by the horizontal sag induced in the cable by the bridge or raft. The anchorage shall be offset from a straight line formed by the unloaded cable in order to ensure that the pull on the anchors and across the towers remains straight when the cable is loaded and sags horizontally. This offset can be found in the table at Fig 6-21.

## TOWER OFFSET

Ser	Velocity (m/sec)	Final horizontal sag (%)	Offset angle (°)	Offset (m/100m from tower)
(a)	(b)	(c)	(d)	(e)
1	1	3	5	9
2	1.5	4	6.5	11
3	2.1	5	8	14
4	2.75	6	9.5	17
5	3.3	7	11	19

Fig 6-21 Tower offset

**ANNEX A**

**DESIGN CALCULATIONS FOR BURIED (DEADMAN)  
ANCHORAGES**

6A-1. **Example Problem.** In the design of buried anchorages many factors must be considered. Some are known through staff channels, some are found by detailed reconnaissance and some are derived from other sources. The detailed design can only be completed once all these factors are known.

6A-2. **Proforma.** The example provided allows detailed design in accordance the principles set down in this chapter.

<b>PROFORMA FOR THE DESIGN OF BURIED ANCHORAGES</b>	
Within this proforma the symbol {} is used to denote the paragraph number or the table (Figure number) from which the required value can be acquired.	
1. RECCE DATA: (water level is datum)	
a. cable type available:	
(1) size	22mm
(2) construction	6 x 19
(3) age	NEW
b. type of soil	Stiff clay
c. baulk(s) available	
(1) type	Round timber
(2) size	0.45m
d. ground water level (GWL)	±0.00m
e. ground elevation (GL)	+2.5m
f. number of cables planned	1
2. DERIVED DATA	
a. strength of cable	
{Fig 3-4-2} $20317\text{kg} \times 9.8\text{m/s}^2 \div 1000$	199 kN
b. age reduction factor {Fig 3-4-3}	1.0
c. fittings reduction factor {Fig 3-4-3}	0.8
d. select lowest reduction factor {2b or 2c}	0.8
e. cable strength {2a} x RF {2d} = $199 \times 0.8 =$	153.9 kN
f. soil factor {Fig 6-13}	0.9
g. shape factor of baulk (round: 0.6; or flat: 1)	0.6

<p>3. KNOWN DATA:</p> <p>a. cable trench width = # of cables <b>{1f}</b> x 0.4 = 1 x 0.4</p> <p>b. minimum clearance above GWL=0.3m</p> <p>c. desired slope of cable (1:4 unless restricted)</p>	<p>0.4m</p> <p>0.3m</p> <p>1:4</p>
<p>4. DETERMINE STRESS ON &amp; DEPTH OF BAULK</p> <p>a. determine maximum depth of baulk (1.6 m is usually sufficient) GL <b>{1e}</b> - GWL <b>{1d}</b> - 0.3 = 2.5 - ±0 - 0.3 =</p> <p>b. select final depth of baulk <b>{Fig 6-12}</b></p> <p>c. determine max allowable load <b>{Fig 6-12}</b></p> <p>c determine final allowable load;</p> <p>d. max allowable load = <b>{4c}</b>x soil factor<b>{2g}</b> = 401.8 x 0.9</p>	<p>2.2 m</p> <p>2 m</p> <p>402 kN/m<sup>2</sup></p> <p>362 kN/m<sup>2</sup></p>
<p>5. DETERMINE DIMENSIONS OF BAULK</p> <p>a. determine total surface area of baulk required to be in contact with face of trench = cable strength <b>{2b}</b>÷ final allowable load <b>{4d}</b> = 16254 ÷ 36900 =</p> <p>b. determine effective height of face of baulk(m) (1) rectangular or square (2) round = diameter x shape factor <b>{2h}</b> = .45m x 0.6 =</p> <p>c. determine required length of baulk = area req <b>{5a}</b>÷ baulk height <b>{5b}</b> + trench width <b>{3a}</b> = 0.44 ÷ 0.27 + 0.4 =</p>	<p>0.44m<sup>2</sup></p> <p>N/A</p> <p>0.27m</p> <p>2.03m</p>
<p>6. DETERMINE SHEAR STRESS ON BAULK = cable strength <b>{2e}</b> ÷ Q = 159.3 ÷ 2 =</p>	<p>79.7kN</p>
<p>7. DETERMINE THE ABILITY OF THE BAULK TO RESIST SHEAR</p> <p>a. determine permissible shear stress <b>{Fig 6-9}</b></p> <p>b. calculate cross sectional area of baulk (1) round = 3.14 x r(m) x r(m) = 3.14 x .225 x .225 =</p> <p>(2) square or rectangular = L x W =</p> <p>c. determine formula to be used <b>{Fig 6-9}</b> S = 0.75 x fs x A = 0.75 x 0.69 x .159 =</p>	<p>fs = 0.69Mpa</p> <p>0.159 m<sup>2</sup></p> <p>N/A</p> <p>82.3 kN</p>

<p>8. CHECK THAT RESISTANCE TO SHEAR IS GREATER THAN FORCE APPLIED BY CABLE                  Force applied {6} must be less than resistance {7c}.  <math>79.65 \text{ kN} &lt; 82.3 \text{ kN}</math>                  If unacceptable, add another cable or increase size of baulk.</p>	<p><b>Acceptable</b> or <b>Unacceptable</b></p>
<p><b>BENDING CHECK</b>                  If length of baulk &gt; 5 x cable trench width, failure through bending will not be a problem.                  A. Baulk length {5c} ÷ 5 =                  B. Trench width {3a} =                  A. &gt; B. <b>YES</b> (No need to calculate bending)  <b>NO</b> (Calculate bending)</p>	
<p>9. DETERMINE BENDING MOMENT APPLIED TO THE BAULK</p> <p>a. determine effective length of baulk  <math>= \{5c\} - \{3a\} = 2.03 - 0.4 =</math></p> <p>b. determine bending force developed by load;  <math>BM(Nm) = 0.5 \times \frac{\text{applied load(N)}}{\text{effective length \{9a\}}} \times \frac{\text{req'd length}^2\{5c\}}{2 \# \text{ of cables \{1f\}}}</math>  <math>= 0.5 \times \frac{16.31}{1.07} \times \frac{1.47 \times 1.47}{2 \times 1} =</math></p>	<p>1.07m</p> <p>16.46kN</p>
<p>10. CALCULATE THE BAULK'S BENDING STRENGTH</p> <p>a. select value of Fc {Fig 6-2}</p> <p>b. select formula to be used {Fig 6-2}</p> $= Fc \times D^3 \div 10 = 8.14 \times (.450)^3 \div 10 =$	<p>8.14Mpa</p> <p>74175. kN</p>
<p>11. CHECK THAT RESISTANCE TO BENDING IS GREATER THAN FORCE APPLIED                  Baulk's resistance {10c} must &gt; bending force applied {9b}. If unacceptable, increase the size of the baulk.</p>	<p><b>Acceptable</b> or <b>Unacceptable</b></p>

Fig 6A-1 Proforma for the design of buried anchorages

## ANNEX B

**DESIGN CALCULATIONS FOR AN ELEVATED CABLE  
ANCHORAGE**

<b>PROFORMA FOR THE DESIGN OF AN ELEVATED CABLE ANCHORAGE SYSTEM</b>	
The symbol {} is used within this proforma to indicate the paragraph or table from which the required value may be acquired.	
1. RECCE DATA: a. width of river = WWG = b. velocity of current = V = c. elevation of home bank (WL=Datum) d. elevation of far bank e. slope of backstay home (consider tail room available) f. slope of backstay far (consider tail room available)	165m 2m/sec +0.5m +1.2m 1:4 1:3
2. KNOWN DATA: a. initial cable sag (2%) b. desired cable sag (5%) c. bridge type	0.02 0.05 Medium(MFB)
3. CABLE SELECTION a. WWG{1a} = 165m. Select next highest length <b>{Fig 6-16}</b> b. bridge type is medium or light. c. $V = \{1b\} \underline{2m/sec}$ For single cable minimum diameter = For double cable minimum diameter = For triple cable minimum diameter = Select (Availability may dictate selection)	183m Medium 26mm 20mm 16mm <u><b>26 mm</b></u>
4. DISTANCE BETWEEN TOWERS a. WWG {1a}+10%+working room on each side = $165 \times 1.1 + 30 = 211.5$ , rounded to b. distance from edge of shore to towers = $(\{4a\} - WWG\{1a\}) \div 2$ $= (212 - 165) \div 2 =$	212m 23.5m
5. INITIAL CABLE SAG $\{4a\} \times 0.02 = 212 \times 0.02 =$	4.24m



Rigging

<p>6. EFFECTIVE TOWER HEIGHTS</p> <p>a. home minimum height          =cablesag+allowance - bankheight{1c}          =4.24m + 1m - 0.5m =</p> <p>b. far minimum height          =cablesag+allowance - bankheight{1d}          =4.24m + 1m - 1.2m =</p>	<p>4.74m</p> <p>4.04m</p>
<p>7. TOWER DISTANCE FROM BRIDGE CENTERLINE</p> <p>a. home bank height at tower is          (1) &lt;4.51m =tower height{6a}+10.6          =4.74 + 10.6 =</p> <p>(2) &gt;4.51m =tower height{6a}+15.25          = N/A</p> <p>b. far bank height at tower is          (1) &lt;4.51m =tower height{6a}+10.6          = 4.04 + 10.6 =</p> <p>(2) &gt;4.51m =tower height{6a}+15.25          = N/A</p>	<p>15.34m</p> <p>14.64m</p>
<p>8. DESIGN ANCHORAGES</p> <p>a. home          (1) select OPH layout - or -          (2) design deadman anchorage # -or-          (3) other anchorage system details</p> <p>b. far          (1) select OPH layout - or -          (2) design deadman anchorage # -or-          (3) other anchorage system details</p>	<p>1</p> <p>2</p>
<p>9. DETERMINE DISTANCE ANCHORAGES FROM TOWER</p> <p>a. home side          =(tower height{6a}+anchorage depth{8a})          x backstay slope{1e}          = ( 4.74 + 1 ) x 4 =</p> <p>b. far side          =(tower height{6b}+anchorage depth{8b})          x backstay slope{1f}          = ( 4.04 + 1 ) x 3 =</p>	<p>22.56m</p> <p>15.12m</p>

<p>10. DETERMINE OFFSET OF ANCHORAGES</p> <p>a. select values {Fig 6-21} based on <math>V</math> {1b}</p> <p><math>V = 2</math> m/sec. Use row Ser (a)3</p> <p>final horizontal sag will be</p> <p>offset angle required is</p> <p>or</p> <p>b. home offset</p> <p>=dist anchor to tower{9a} x offset(m) {10a}÷100</p> <p>= 22.56 x 14 ÷ 100 =</p> <p>c. far offset</p> <p>=dist anchor to tower{9a} x offset(m) {10a}÷100</p> <p>= 15.12 x 14 ÷ 100 =</p>	<p>2.1m/sec</p> <p>5%</p> <p>8°</p> <p>14m/100m</p> <p>3.2m</p> <p>2.1m</p>
<p>11. CONSTRUCTION DIAGRAM</p> <p>Not to Scale</p>	

Fig 6B-1 Proforma for the design of an elevated cable anchorage system

**CHAPTER 7**  
**BLOCKS AND TACKLES**  
**SECTION 1**  
**TACKLES**

**GENERAL**

7-1-1. Tackles are an arrangement of blocks and SWR or cordage used to gain a mechanical advantage when lifting or pulling. The most commonly used tackles in field engineering tasks are those for lifting or running as shown below.

**TERMINOLOGY**

7-1-2. The following terms are used in relation to tackles:

- a. **Block.** A block is a wood or metal frame enclosing one or more rotating pulleys;
- b. **Fixed Block.** The fixed block is the block in a tackle system that is anchored and does not travel while the system is in use;
- c. **Moving Block.** The moving block is the block in a tackle system to which the load is attached. It moves when the system is in use;
- d. **Fall.** The fall is the SWR or cordage connecting the blocks;
- e. **Return.** A return is any single part (SWR or cordage) of the fall;

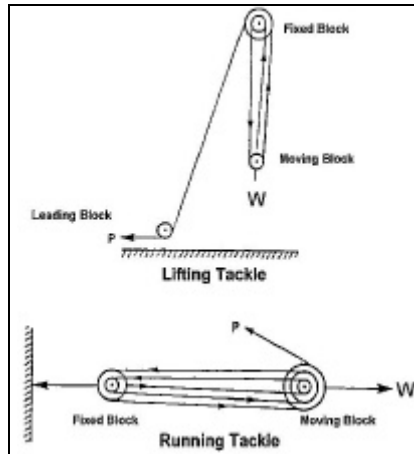

Fig 7-1-1 Lifting and running Tackles

- f. **Standing End.** The standing end is the end of the fall that is made fast to one of the blocks in the tackle system;
- g. **Running End.** The running end is the loose end of the fall to which the power (pull) is applied;
- h. **Lifting Tackle.** A lifting tackle is one in which the running end of the fall comes off the fixed block. It is normally used vertically;
- j. **Running Tackle.** A running tackle is one in which the running end of the fall comes off the moving block. It is normally used horizontally;
- k. **Reeving.** Reeving is the action of passing the fall around the sheaves of the blocks when making up the tackle;
- m. **Overhauling.** Overhauling a tackle is the action of separating the two blocks in a tackle system;
- n. **Rounding In.** Rounding in is the action of bringing together the two blocks in a tackle system;
- p. **Chock-a-Block.** When the two blocks in a tackle system are rounded in to their maximum, they are termed chock-a-block;
- q. **Rack.** To rack a tackle, any two opposite returns are seized to prevent it from overhauling when the running end is released;
- r. **Leading Block.** A leading block is a block used to change the direction of the running end of a tackle so the power may be more conveniently applied. Snatch blocks are normally used;
- s. **Shell.** Another term for the frame containing the rotating pulleys;
- t. **Becket.** A round metal thimble permanently attached to the bottom of the shell to which the standing end of the cordage or SWR is attached;
- u. **Sheaves.** Another term for the rotating pulleys; and
- v. **Loft.** The distance between the blocks of a tackle system.

## BLOCKS

7-1-3. Blocks are used in a tackle to change the direction of the SWR or cordage. The basic parts of a block are illustrated above. Blocks are designated according to the number of sheaves; thus a double block has two sheaves. Snatch blocks differ slightly in that they have a hinged or sliding gate

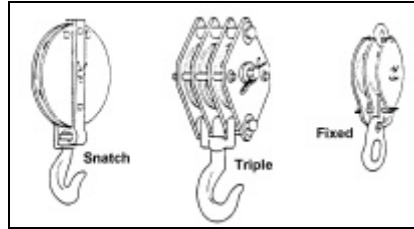

Fig 7-1-2 Types of blocks

forming part of the shell. The gate can be opened to allow the SWR or cordage to be passed over the sheave, without having to thread the whole piece of SWR or cordage through the block. This enables snatch blocks to be incorporated into a tackle system that has already been rigged. Snatch blocks are almost always single sheaved. Dual snatch blocks exist but are not in CF inventory.

## TACKLES

7-1-4. Tackles can be made up in various combinations. A system that incorporates a single block and a double block is called a double/single tackle. Similarly, a system having two triple blocks is called a triple/triple tackle. They are written as 2/1 and 3/3 tackles respectively.

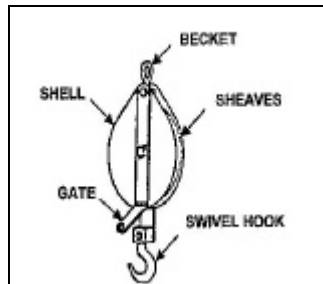

Fig 7-1-3 Parts of a snatch block

## CARE OF TACKLES

7-1-5. If tackles are to work efficiently, all friction losses must be reduced to a minimum. This can be achieved by ensuring the correct size blocks are used and observing the following rules:

- a. blocks are well lubricated and free from grit and dirt. If blocks squeak they are not in good working order;
- b. the fall is free from kinks and twists, and runs freely over the sheaves;
- c. tackles are carried and not dragged along the ground; and

- d. tackles are prevented from twisting.

### **SAFETY PRECAUTIONS**

7-1-6. The following safety precautions apply to the operation of both lifting and running tackles:

- a. when overhauling a tackle under tension, a turn shall be taken with the running end around a belaying picket to prevent the weight on the tackle taking charge. Similarly when rounding in, one person is detailed to take in the spare cordage and to keep a turn around the belaying picket;
- b. when the fall is taut, it shall not be jarred by being struck or by men treading on it;
- c. the returns shall not be handled when moving unless absolutely necessary;
- d. suspended weights shall be lowered uniformly and not with a jerking motion; and
- e. when working near the safe limit of a tackle, and before leaving it under strain, the tackle shall be eased off slightly in order to distribute the stress equally between the returns.

### **PULL APPLIED BY PERSONNEL**

7-1-7. The number of personnel available to apply pull is often the limiting factor in the design of the system. A perfectly designed and constructed system that cannot be operated by the personnel available is of no use. Pull applied vertically is further limited to the number of personnel that can grip the running end. The maximum number of personnel that can apply pull vertically is three. Each can apply 45 kg of pressure. Therefore, any system that requires more than 135 kg of pressure to operate requires that the pull be applied horizontally. Personnel hauling horizontally can apply 35 kg of pressure each. The number of personnel is unrestricted except by the limitations of the site.

## SECTION 2

### MAKING TACKLES

#### SELECTING THE BLOCK

7-2-1. It is most important that the correct block is selected. Most blocks have their SWL and the size of SWR or cordage, for which they are designed, marked on the shell. If it is not marked, a suitable block can be selected by ensuring that:

- a. approximately one-third of the circumference of the SWR or cordage is in contact with the sheave (below); and
- b. the diameter of the sheave is not less than nine times the diameter for cordage and 18 times the diameter for SWR.



Fig 7-2-1 Correct and incorrect sheaves for a rope

#### REEVING CORDAGE TACKLES

7-2-2. Reeving a tackle is normally a two-man operation. The two blocks are placed on their sides with the hooks pointing outwards and the blocks held in position with pickets. The coil of the cordage is placed to the side of the block from which the running end will come. The blocks are then reeved as shown in Fig 7-2-2. (Note that the running end comes from the centre sheave of a triple block). This manner of reeving evens out the stresses involved and makes an anti-twister unnecessary. The standing end is made fast to the becket with two half-hitches and seized. The half-hitches shall be as close to the block as possible with very little spare cordage left for seizing so that the blocks will not become chock-a-block too soon. In order to save overhauling after reeving, all tackles shall be reeved in this manner, except for long heavy tackles which are better reeved with the blocks the working distance apart .

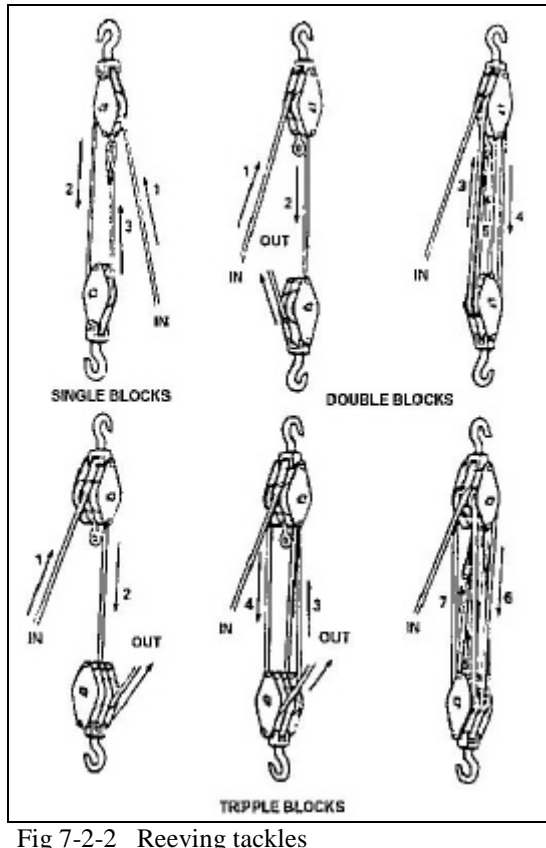

Fig 7-2-2 Reeving tackles

## STEEL WIRE ROPE TACKLES

7-2-3. The process of reeving a SWR tackle is similar to that of cordage except that the standing end is fixed to the becket using clips. The spacing of the clips will therefore govern the chock-a-block position.

## ANTI-TWISTERS

7-2-4. Some tackles tend to twist when power is applied, owing to the lay of the SWR or cordage and the uneven tension in the falls. New SWR or cordage and long tackles are more liable to twist than old SWR and cordage and short tackles, but in most cases an anti-twist device will still be required.



7-2-5. **Horizontal Anti-Twister.** An effective anti-twister for a horizontal or sloping tackle is shown below. It consists of a maul with the helve secured firmly to the standing end of the fall where it is attached to the bucket. The end of the helve projects above the returns of the tackle and the suspended weight of the maul head counteracts the tendency to twist. In long tackles, if the head of the maul proves to be too light, an additional weight shall be secured to it or a crowbar used instead.

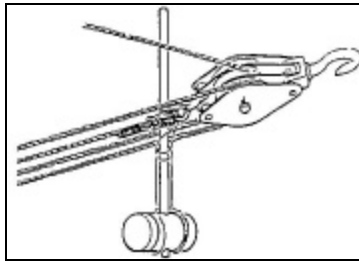

Fig 7-2-3 Horizontal tackle anti-twister

7-2-6. **Vertical Anti-Twister.** For a vertical tackle, the type of anti-twister shown below shall be used. A horizontal light spar or picket is substituted for a maul and fixed in similar fashion to the picket and standing end. The tackle is prevented from twisting by personnel holding reins attached to the ends of the spar.

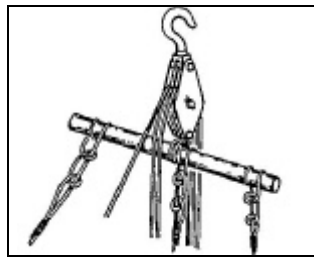

Fig 7-2-4 Vertical anti-twister

## BLOCK LASHING

7-2-7. The fixed block or the leading block in a tackle is normally lashed to a fixed point. The method of doing this is illustrated in Fig 7-2-5. Start the lashing with a clove hitch above the hook and marry the ends. Apply the number of turns required around the hook and spar then finish off with two half-hitches around the spar below the hook. The calculations necessary to determine the number of lashing turns required are contained at Annex A to Chapter 8.

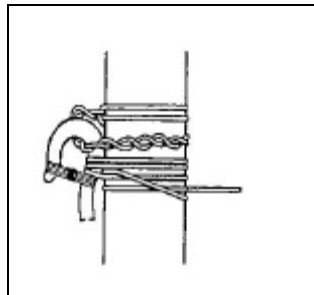

Fig 7-2-5 Lashing a block to a spar

**MOUSING**

7-2-8. Mousing the hook of a block is closing the hook opening using twine. This prevents a sling jumping off when the load is released. The traditional way of mousing is illustrated in Fig 7-2-6. An alternative, more commonly used method is shown in Fig 7-2-7 but shall only be used when lashing a block to a spar. As shown in Fig 7-2-6 a sling can jump over the frapping turns.

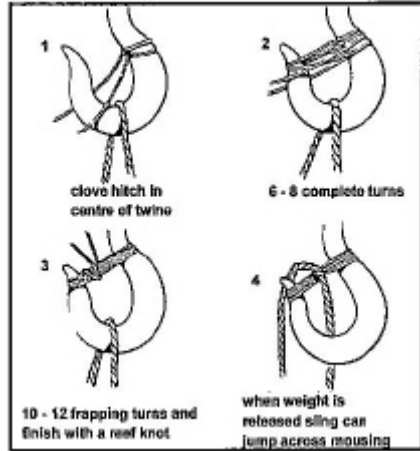

Fig 7-2-6 Mousing a hook

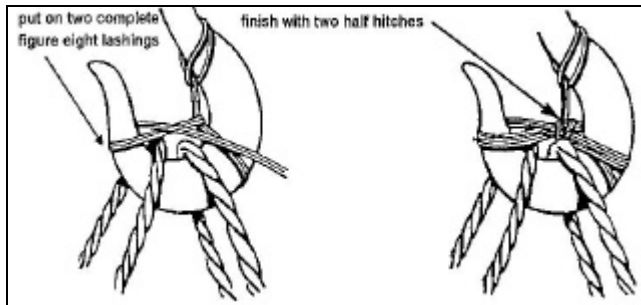

Fig 7-2-7 Alternate method of mousing a hook

**SECTION 3**

**MECHANICAL ADVANTAGE OF TACKLES**

**GENERAL**

7-3-1. Tackles are made up in various combinations to provide a mechanical advantage. This section covers the calculation of the mechanical advantage of tackle systems.

**THEORETICAL GAIN**

7-3-2. The mechanical advantage of a tackle is the ratio of weight to applied pull . If there was no friction or other loss of efficiency, the mechanical advantage (MA) would equal the theoretical gain (G).

**MECHANICAL ADVANTAGE FORMULA**

Formula	Meaning of Symbols
Mechanical Advantage= $\frac{W}{P}$	Where W =Weight of object P =Applied pull

Fig 7-3-1 Formula for determining the mechanical advantage of tackles

7-3-3. As the tension in any rope is theoretically constant throughout its length, the tension in all the returns of the fall are considered to be equal. Therefore G is determined by the number of returns at the moving block, including the standing end made fast at either block (Fig 7-3-2). The value of G for various tackle combinations is shown in Fig 7-3-3.

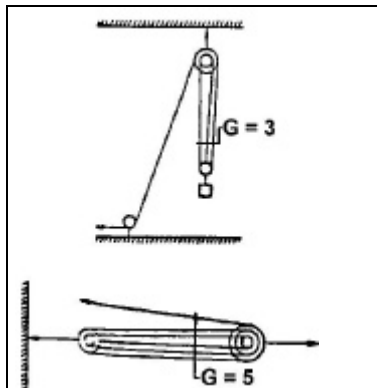

Fig 7-3-2 Number of returns of the fall at the moving block

ADVANTAGE OF COMMON TACKLES

Ser	Configurati on	Lifting Tackle		Running Tackle	
		Theoretical Gain	Practical Gain	Theoretical Gain	Practical Gain
(a)	(b)	(c)	(d)	(e)	(f)
1	2/2	4	2.7	5	3.6
2	3/2	5	3.1	6	4.0
3	3/3	6	3.5	7	4.4

Fig 7-3-3 Commonly used tackles

COEFFICIENT OF FRICTION

7-3-4. The coefficient of friction (f) represents the proportion of the overall effort that is lost due to friction and other losses in the system. This varies between 10 to 20 % depending on the state of the rope and the blocks. Beyond a 20% loss of friction the blocks shall be exchanged, repaired or condemned.

COEFFICIENT OF FRICTION

Ser	Blocks	Coefficient of Friction
1	good condition	0.1
2	flexible SWR, cordage blocks in fair condition	0.15
3	worn, dirty, or twisting blocks, or incorrect block and cordage size	0.2

Fig 7-3-4 Coefficient of friction

CALCULATIONS

7-3-5. Examples can be found in Chapter 6. The formula for calculating the pull required in any pulley system is:

REQUIRED PULL FORMULA

Formula	Meaning of Symbols
$P = \frac{W}{G} (1 + fn)$	Where f =coefficient of friction n =total number of sheaves including any lead blocks W =weight of object (kg) P =applied pull (N) G =Theoretical Gain

Fig 7-3-5 Required pull formula

**LIMITING FACTORS**

7-3-6. The factors that affect the maximum load that may be applied to a given tackle are:

- a. Block Strength (Fig 7-3-6);
- b. SWR or Cordage Strength;

**SAFE WORKING LOAD OF BLOCKS**

Ser	Rope dia. (mm)	SWL - (t)					
		Blocks for fibre ropes			Blocks For SWR		
		Snatch	Double	Triple	Snatch	Double	Triple
1	8	-	-	-	1.0	1.75	2.75
2	12	0.2	0.3	0.4	2.0	5.0	7.0
3	16	0.3	0.4	0.6	4.0	10.0	15.0
4	24	0.8	1.2	1.8	9.0	15.0	25.0
5	26	1.0	1.4	2.1	-	-	-
6	32	1.2	1.8	2.7	16.0	25.0	35.0
7	40	2.4	3.3	5.3	-	-	-

Fig 7-3-6 SWL of blocks

- c. Anchorage Strength. The pull on an anchorage to which a fixed block is secured is as follows:

**PULL ON ANCHORS**

Tackles		Leading blocks	
Lifting	Running	Up to 90°	Over 90°
W + P	W - P	1.5 P	2 P

Fig 7-3-7 Pull on anchors

- d. **Lashing Strength.** The pull on a lashing securing a fixed block in a tackle system is the same as the pull on the anchorage. The number of turns required to secure a block with a lashing can be calculated using the design tables in Chapters 2 or 3. Allowance is to be made for unequal distribution of stress and sharp bends. These reduction factors are described in Chapters 2 and 3; and
- e. The minimum number of turns is 4. The formula for calculating the required number of turns (N) is:

NUMBER OF TURNS FORMULA

Formula	Meaning of Symbols
$N = \frac{W + P}{\text{Number of Returns} \times \text{Pull} \times \text{Reduction Factors}}$	Where N = Number of turns W = Weight P = Pull

Fig 7-3-8 Number of turns required

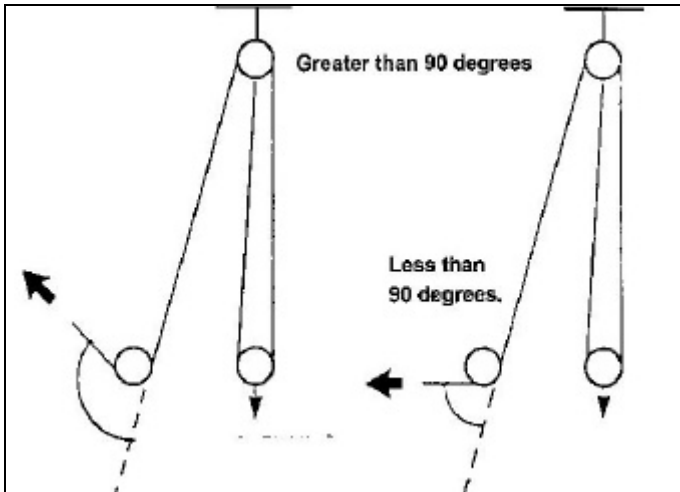

Fig 7-3-9 The pull on a leading block

**ANNEX A**

**EXAMPLE TACKLE DESIGN**

7A-1. This example covers all aspects of the design of a compound tackle system and can be used as a comprehensive guide.

7A-2. The example problem consists of a weight of 1750 kg to be lifted 11 m by no more than eight personnel. The rope available is new nylon. There are two triple, four double, and two snatch blocks available. All are in fair condition.

7A-3. Initially a simple system with the maximum G is proposed and checked to determine if the number of persons available can operate the system. A 3/3 running system is tried and found to require each of the three persons operating the system to pull about 158 kg; far too much. Next a 3/3 lifting tackle is tried and found to require a pull of 554 kg. This will require 16 persons to operate which exceeds the power available. It is now obvious that a compound system is necessary. Within the limitations of available blocks and practicality, the best system possible is a 3/3 lifting operated by a 2/2 running. A leading block will be necessary.

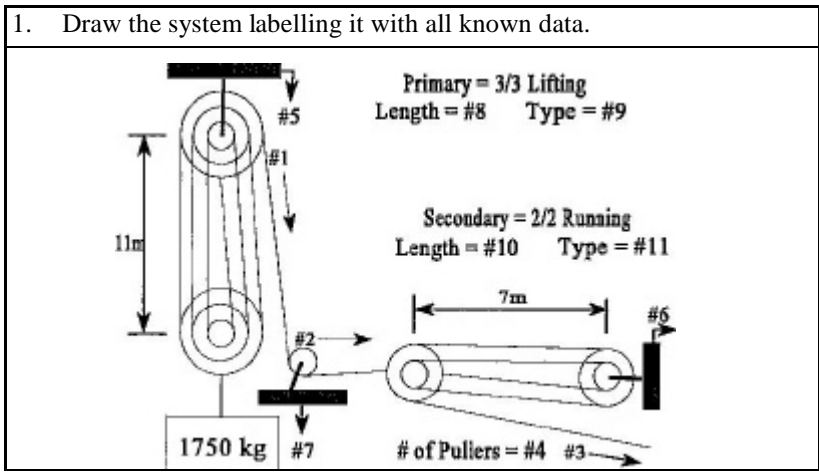

<p>2. List the values to be determined.</p> <p>{# 1} = Pull on the primary fall line before the leading block.                  {# 2} = Pull on the primary fall line after the leading block.                  {# 3} = Pull on the secondary fall line.                  {# 4} = Number of pullers required to lift the load.                  {# 5} = Pull on the primary system's anchor.                  {# 6} = Pull on the secondary system's anchor.                  {# 7} = Pull on the snatch block's anchor.                  {# 8} = Length of primary system rope.                  {# 9} = Primary system rope size and type.                  {# 10} = Length of secondary system rope.                  {# 11} = Secondary system rope size and type.</p>	
<p>3. Calculate the pull on the primary fall line prior to the leading block <b>{#1}</b>.</p> $P = ( W \div G ) [ ( 1 + f ) n ]$ $P = ( 1750 \div 6 ) [ ( 1 + 0.15 ) 6 ] =$	<p>554.17kg</p>
<p>4. Calculate the pull on the primary fall line after the leading block.<b>{#2}</b>. Weight is equal to the pull required prior to the block, which provides no mechanical advantage.</p> $P = ( W \div G ) [ ( 1 + f ) n ]$ $P = 554.17 ( 1 + 0.15 \times 1 ) =$	<p>637.3 kg</p>
<p>5. Calculate the pull on the secondary fall line <b>{#3}</b>.</p> $P = ( W \div G ) [ ( 1 + f ) n ]$ $P = ( 637.3 \div 5 ) [ ( 1 + 0.15 ) 4 ] =$	<p>203.9 kg</p>
<p>6. Calculate the number of pullers required to lift the load <b>{#4}</b>.</p> $203.9 \text{ kg} \div 35 =$	<p>6 required</p>
<p>7. Calculate the pull on the primary anchor <b>{#5}</b>.</p> <p>(Load + 10%) + Pull</p> $1750 + 175 + 554.17 = 2479.14 \text{ rounded to}$	<p>2479 kg</p>
<p>8. Calculate the pull on the secondary anchor <b>{#6}</b>.</p> <p>(Load + 10%) + Pull</p> $637.3 + 63.7 + 203.9 = 904.9 \text{ rounded to}$	<p>905 kg</p>
<p>9. Calculate the pull on the leading block anchor <b>{#7}</b>.</p> <p>Load x 2</p> $637.3 \times 2 = 1274.6 \text{ rounded to}$	<p>1275 kg</p>



Rigging

<p>10. Calculate the length of the rope in the primary system <b>{#8}</b>.          Loft x # of returns x 1.25  <math>11 \times 7 \times 1.25 = 96.25</math> m rounded to</p>	<p>97 m</p>
<p>11. Select type of rope to be used in primary system <b>{#9}</b>.          Greatest tension in system = 637.3 kg  <math>MBS = SWL \times FS \div RF</math>  <math>MBS = 637.3 \times 5 \div 0.9 = 3540.56</math> rounded to 3541 kg          From appropriate table select</p>	<p>16 mm Nylon.</p>
<p>12. Calculate the length of the rope in the secondary system <b>{#10}</b>.          Loft x # of returns x 1.25 + number of pullers  <math>7 \times 5 \times 1.25 + \text{number of pullers} =</math>  <math>35 \times 1.25 + 6 = 49.75</math> rounded up to</p>	<p>50 m</p>
<p>13. Select type of rope to be used in secondary system <b>{#11}</b>. Greatest tension in system = 203.9 kg  <math>MBS = SWL \times FS \div RF</math>  <math>MBS = 203.9 \times 5 \div 0.9 = 1132.78</math> say 1133 kg          From table 2-6-2 select</p>	<p>16 mm Nylon.</p>
<p>14. Check block strength</p> <p>a. Tension on main cable <b>{para 3}</b> 554.17 kg          Diameter of main cable <b>{para 11}</b> 16 mm          SWL from <b>Fig 7-3-5</b> 0.6 t or 600 kg</p> <p>b. Tension on secondary cable <b>{para 5}</b> 203.9 kg          Diameter of secondary cable <b>{para 13}</b> 16 mm          SWL from <b>Fig 7-3-5</b> 0.4 t or 400 kg</p> <p>If load on blocks exceeds SWL, increase the size of the rope being used.</p>	<p>Safe to Use</p> <p><b>YES</b> <del>NO</del></p> <p><b>YES</b> <del>NO</del></p>

Fig 7A-1 Proforma for tackle systems design

**CHAPTER 8**  
**FIELD MACHINES**  
**SECTION 1**  
**STANDING DERRICKS**

**DESCRIPTION**

8-1-1. A standing derrick is a single vertical spar, that is kept upright by guys, and has a lifting tackle lashed to its head. Four guys are normally required, at right angles to each other in plan, but sometimes the back guy may be split. A standing derrick is used for raising loads where the radius of action required is small. The load can be moved only to a distance of one-third of the effective height of the derrick.

8-1-2. The fixed block of the lifting tackle may be lashed to the spar, suspended by a sling passing through a slot in the head of the spar, or attached by shackles to a special head ring. The fall passes through a leading block lashed to the foot of the derrick.

**GUYS**

8-1-3. A running guy is a guy that has a tackle in it enabling it to be adjusted. Running guys, preferably of SWR, are used for all guys on which tension will be applied. The guys are secured to the head of the derrick, as nearly opposite one another and as near to the point of attachment of the lifting tackle, as possible.

8-1-4. When a guy can not be anchored at its correct location a split guy may be used. Two holdfasts are placed symmetrically on either side of what would have been the centre line of the single guy. The rope passes from one holdfast, around a snatch block lashed to the head of the derrick and back to a tackle fixed to the other holdfast with an angle between 45E and 60E.

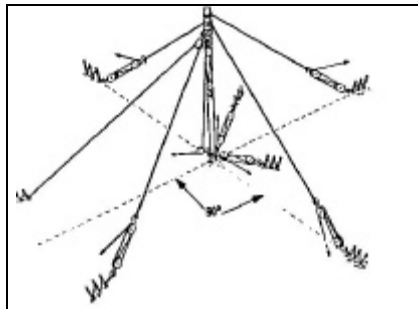

Fig 8-1-1 Standing derrick with a split back guy

## Rigging

8-1-5. Single, or double splayed at 90E, foot ropes will always be necessary. Normally 24 mm diameter cordage 3/3 tackles shall be used. The surface under the derrick should be firm and the butt shall be placed in a hole about 0.3 m deep. Footings may be necessary.

### CONSTRUCTING A DERRICK

8-1-6. Lay out the guys, anchorages, and tackles (Fig 8-1-1).

8-1-7. Light derricks may be raised by hand, but heavier derricks shall be raised with the help of a lever, separate derrick or a crane. A moving lever is one which is tied into the back guy with a slip knot. It can be stabilized with guys of its own if necessary. It will rise off the ground when of no further use and may then be released by the slip knot. A fixed lever may also be used but is generally more complicated to construct.

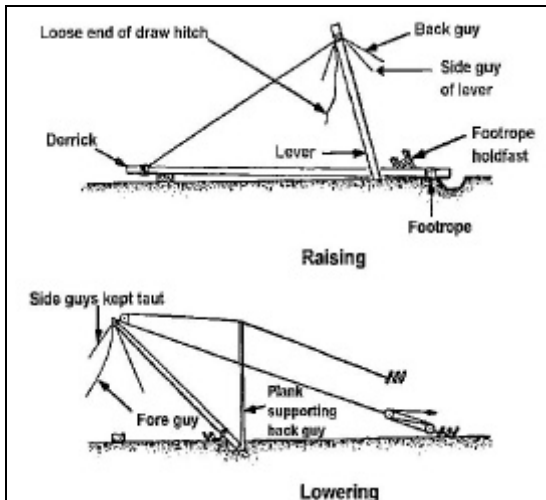

Fig 8-1-2 Methods of raising and lowering a derrick

8-1-8. Derricks can be erected in one place and walked to another but great attention must be paid to safety. All guys shall be manned at all times and the butt will be controlled with foot ropes.

8-1-9. **Lowering a Derrick** is done in a similar manner to raising it, except that the process is reversed. Packing shall be placed to support the head of the derrick when lowered. The foot ropes are taken in as the

derrick comes down. If the derrick is not very heavy, a plank may be used as a lever with one end butted against the foot of the derrick and the other under the standing end of the guy. The plank shall be nearly vertical (Fig 8-1-2).

## SECTION 2

### SHEERS

#### DESCRIPTION

8-2-1. Sheers consist of two upright spars with their butts separated and their tips lashed together. They are held upright by a fore and back guy (Fig 8-2-1). The two spars are each lighter than the one required for a standing derrick. Sheers can often be employed where the use of a derrick would be impossible. On the other hand, they can only be used to move the weight in a straight line by swinging the load between the legs

#### CONSTRUCTION SEQUENCE

8-2-2. Lay the two spars with their butts flush together on the ground and supported on a baulk near their tips. Do not lash over bark.

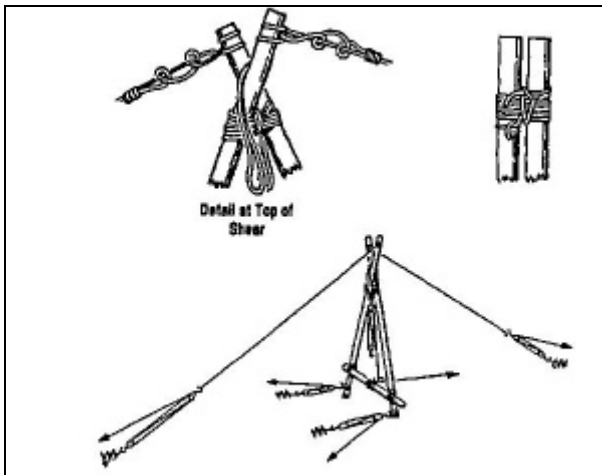

Fig 8-2-1 Sheers

8-2-3. Make a clove hitch round one spar about 1 m from the tip, and take the rope loosely six or eight times round both spars above the clove hitch. Spacers roughly one-third the diameter of the spars may be used to ease the construction of this lashing. Take two frapping turns round the lashing and make the end of the rope fast to the other spar by two half-hitches just above the lashing.

8-2-4. Separate the butts until their distance apart is about one-third of the length of the spars from butt to lashing. With large spars the butts shall be opened out to nearly the full distance before the lashing is fixed, as it will otherwise be too taut. Lash on a ledger with square lashings 0.5 m up from the butt in order to prevent them from splaying.

8-2-5. Pass a sling over the fork so that it rests across the spars and not on the lashing between the spars. Hook the lifting tackle into the sling. Cleats may be nailed to one spar to enable personnel to climb to the top.

**TENSION**

8-2-6. The loaded tension of the main cable will dictate the field machine’s design. The tension can be substituted for the maximum weight to be lifted. This can be converted to maximum force induced to select spar and guy sizes. To select the size of spar to use, the loaded tension is multiplied by the factor from the table in Fig 8-2-2 and applied to the table at Fig 8-2-3 along with the effective length of the spar or leg. Annex A to Chapter 9 offers an example of a detailed sheer design.

**FORCE INDUCED IN SPARS AND GUYS BY LOADS**

Ser	Item	Maximum Force Induced		
		Derrick	Sheer	Gyn
(a)	(b)	(c)	(d)	(e)
1	Leg	2.0	1.0	0.4
2	Leg with Leading Block		1.2	0.6
3	Guys taking Weight	0.7	0.7	
4	Other Guys	0.3	0.3	

Fig 8-2-2 Force induced in spars and guys by loads

## MAXIMUM LOAD (KN) ON SPARS OF VARIOUS LENGTHS AND DIAMETERS

Ser	Spar Mean Diameter (mm)	EFFECTIVE LENGTH OF SPAR (m)																
		3	4	5	6	7	8	9	10	11	12	13	14	15	16	17	18	
(a)	(b)	(c)	(d)	(e)	(f)	(g)	(h)	(j)	(k)	(l)	(m)	(n)	(p)	(q)	(r)	(s)	(t)	
1	150	39.6	24.5	15.6	10.7													
2	175	67.6	45.	28.4	19.6	4.7												
3	200	99.8	65.8	47.0	33.3	24.5	19.6											
4	225	138.1	106.8	76.4	54.8	42.1	31.3	24.5										
5	250	180.4	147.0	109.7	81.3	61.7	46.0	37.2	30.3									
6	275	228.3	194.0	154.8	119.5	88.2	66.6	55.8	48.0	37.2								
7	300	278.3	246.9	205.8	158.7	126.4	98.0	79.3	69.5	53.9	44.1							
8	325	338.1	300.8	256.7	208.7	170.5	133.2	107.8	85.2	74.4	58.8	51.9						
9	350	396.9	362.6	231.2	267.5	215.6	176.4	141.1	118.6	98.9	81.3	68.6	59.7					
10	375	460.6	431.2	386.1	332.2	277.3	227.3	182.2	153.8	128.3	108.7	89.1	79.3	68.6				
11	400	495.8		450.8	399.8	343.0	281.2	242.0	191.1	163.6	140.1	117.6	99.9	90.1	78.4			
12	425				471.3	420.4	355.7	292.0	247.9	202.8	177.3	151.9	126.4	113.6	100.9	89.1		
13	450						498.8	428.2	364.5	305.7	256.7	220.5	192.0	163.6	142.1	127.4	113.6	98.9

NOTES: 1. Effective length means unsupported length, eg. Between restraining guys and foot ropes.  
2. Effective length divided by the diameter must not be greater than 40.  
3. Assumes SC3 timber.

Fig 8-2-3 Maximum load (kN) on spars of various lengths and diameters

**GUYS**

8-2-7. Sheer guys are similar to guys required for a derrick. They shall be made fast near the tops of the spars by clove hitches. To ensure that they will draw the spars together when the tension is applied the fore guy is lashed to the rear spar and the back guy to the front spar.

8-2-8. When using sheers at the edge of a wharf, pier, building roof or cliff top, the fore guy may be dispensed with, but the sheers shall always lean distinctly outwards, while never exceeding an incline of one third of the effective height.

## **SETTING UP**

8-2-9. Sheers may be raised and lowered in a similar manner to derricks, except that they are nearly always too heavy to be raised by hand. Sheers may be walked in a similar manner to derricks.

8-2-10. Foot ropes and footings similar to those required for a derrick may be required, and the butts may be sunk, ground permitting.



## SECTION 3

### GYNS

#### DESCRIPTION

8-3-1. A gyn consists of three spars lashed together at the tips, the butts forming an equilateral triangle on the ground. No guys are required and the space occupied is small. Only vertical lift is possible. The lifting tackle is suspended from a sling passed over the crook formed by the tips of the spars.

#### CONSTRUCTION SEQUENCE

8-3-2. Lay out the three spars with their butts flush, and mark the point of the centre of the lashing, about 1 m from the tip of the spars.

8-3-3. Leave the two outside spars where they are, more than their own diameter apart. Lay the centre spar between them with its butt in the opposite direction, ensuring that the marks on the three spars are in line. Support the tips of the spars on a baulk, and do not lash over bark.

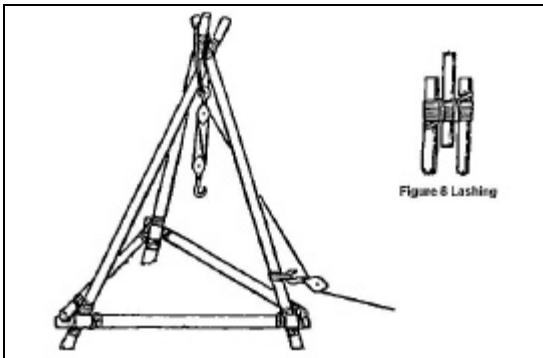

Fig 8-3-1 Gyn

8-3-4. Make a clove hitch on one of the outside spars below the lashing and take the cordage over and under the three spars loosely six or eight times. Take a couple of frapping turns round the lashing between each pair of spars in succession and finish off with two halfhitches on the other outside spar above the lashing.

8-3-5. Cross the two outer spars, or cheeks, until their butts are at a distance apart equal to about half the effective length of the spars. Lash a ledger with square lashings across the cheeks about 0.5 m from their butts.

8-3-6. Lay the sling across the top lashing at right angles to the spars, with the centre of the sling in the centre of the lashing.

8-3-7. The head shall be lifted as far as possible by hand and the centre spar, or prypole, brought in towards the centre of the ledger already fixed, either by a handspike lashed across it or by a tackle. If the other end of the tackle is to be attached to the ledger, this fact shall be allowed for in determining its diameter.

8-3-8. When the butts form an equilateral triangle, two more ledgers are lashed across the butts of the legs.

8-3-9. The figure eight lashing at the head may be prevented from slipping during erection and dismantling by driving a stout nail or spike into the centre spar below the lashing.

8-3-10. Footings and foot ropes will be required and the feet are to be on the same level and properly supported. They must be secured from slipping.

## **WORKING WITH GYNS**

8-3-11. The gyn is placed with its head over the centre of gravity of the load to be raised. If the load has to be swung, the head shall be symmetrical about the points for raising and lowering it.

8-3-12. A suspended load can be hauled straight towards the centre of any upright spar without risk of upsetting the gyn, but hauling it to either flank, or taking a swinging lift, is liable to cause the gyn to tip. If there is a risk of the gyn tipping, light guys will be used.

8-3-13. Light gyms can be carried horizontally for short distances. On good ground, a gyn may be hauled into position by drag-ropes attached to the bottom of the spars. It should be moved with one foot leading.

## **DESIGN**

8-3-14. Annex A to Chapter 9 offers an example of a gyn design.

## CHAPTER 9

### ELEVATED CABLES

#### GENERAL

9-1. Elevated cables provide a quick and simple means of transporting light loads across gaps. They are useful, particularly in rocky or mountainous country, in many circumstances including crossing dry gaps, as a means of communication before a bridge is built, or as an aid to the actual bridge building. They can be used as an alternative to porter or pack transport in mountainous terrain.

9-2. The simple elevated cable across a near level gap consists of a single cable, supported and anchored at both ends, on which runs a snatch block, or traveller, to carry the load, which is hauled across the gap with ropes. The difference in elevation of the cable supports should not exceed  $\frac{1}{25}$ th (4%) of the span. A ropeway of this kind is shown below.

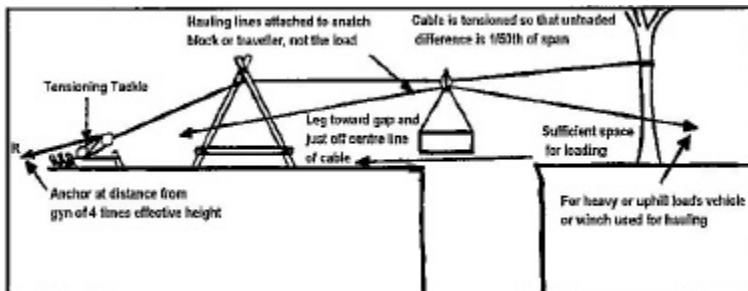

Fig 9-1 Simple elevated cable

#### DESIGN

9-3. An example design of an elevated cable is shown in Annex A to this chapter.

9-4. **Selection of Site.** A smooth landing and loading space on each side of the gap is essential. A space of 6m is required on each bank for construction room. Consider also transport access at the far end for continuation of the journey. The existence of a stout, well-rooted tree on the far bank may solve the problem of supporting the cable. Once the position of the supports has been determined, the gap can be measured and the design commenced.

9-5. **Selection of Cable.** The availability of cable may decide the maximum load that can be carried.

## CONSTRUCTION

9-6. **Fixing the Cable.** If a natural support is not available, a gyn (or sheer) shall be erected. A gyn is better as it is more stable than a sheer and does not need guys. The position and height of the support must be calculated to allow for easy attachment and detachment of the load. The gyn may be made of timber spars or tubular scaffolding. It shall be erected so that one leg is towards the gap and just off centre of the line of the cable. The cable passes through a snatch block slung from the crook of the gyn to an anchorage sited at a distance from the gyn (or sheer) of not less than four times its effective height. (In restricted areas, a slope up to 1 in 2 is acceptable if the anchor will facilitate it). For design of the anchorage and sling for the snatch block see Chapters 5, 6 and 7. On the home bank, a tackle is interposed between the cable end and the anchorage as a tensioning device.

9-7. **Composition of the Traveller.** The traveller requires two hauling ropes to reach across the gap (provide ample spare end) and a lifting tackle to lift the load. For light loads on a level gap, a single snatch block traveller is adequate, but for heavier loads and for ropes on slight slopes, a two-block traveller is better. For steep hillsides a specially made pulley and strap are necessary. Travellers are illustrated here. Before fixing a traveller to the cable, be certain that it is made fast by the hauling cable to a holdfast on the bank.

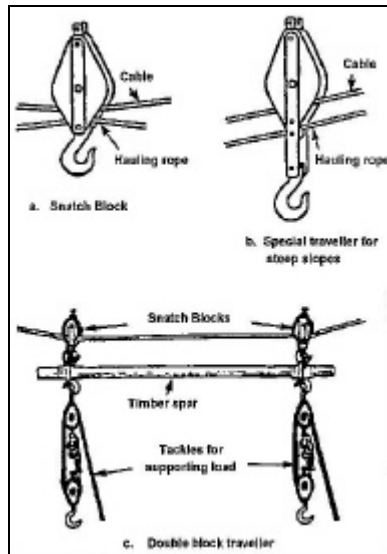

Fig 9-2 Travellers for elevated cables

9-8. If the ropeway is up a steep slope, mechanical power may be needed to traverse the load. If that is not practicable, as for instance in mountainous country, the hauling rope must be led back to the bottom end. This usually introduces two new problems the anchorage at the top end in a restricted area and the extra long hauling cable. The former may be

## Rigging

overcome by the use of a rock anchorage; the latter will probably involve splicing. An example of top end arrangement is illustrated below.

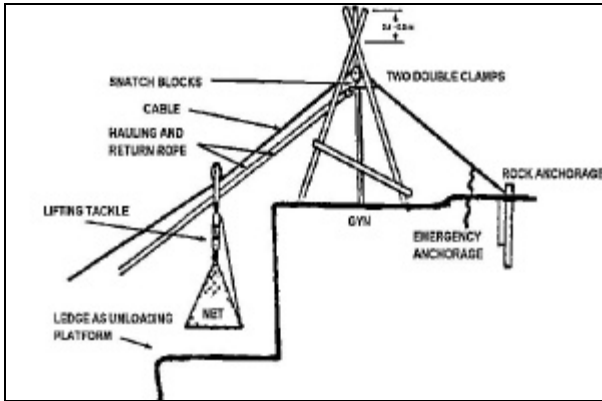

Fig 9-3 Top end arrangement of elevated cable

9-9. The table at Fig 9-4 gives the maximum concentrated load on suspended cables according to diameter and tension of the cable and to the length of span. The table at Fig 9-5 gives the unloaded tension of suspended cables.

### MAXIMUM CONCENTRATED LOADS ON SUSPENDED CABLES

Ser	Diameter of SWR (mm)	Tension on cable (N)	SWL on Cable (kg)					
			Span(m)					
			50 m	100m	150m	200m	250m	300m
(a)	(b)	(c)	(d)	(e)	(f)	(g)	(h)	(j)
1	8	5.39	90	80	75	70	65	60
2	12	11.76	200	185	170	160	150	135
3	16	20.58	350	330	310	285	265	240
4	20	32.34	550	515	480	445	410	375
5	24	46.06	790	720	690	640	590	540

- NOTES
1. The difference in level of the cable supports should not generally be greater than  $1/25$  of the span.
  2. The cable is assumed to be tensioned so that unloaded the sag is  $1/50$  of the span. The sag with the load at the centre will than be approximately  $1/20$  of the span.
  3. This table shows the mass in Kg which can be supported. The load in N can be calculated by multiplying this mass by  $9.8 \text{ m/s}^2$

Fig 9-4 Maximum concentrated loads on suspended cable

## UNLOADED TENSION OF SUSPENDED CABLES

Ser	Cable Mass (kg/ 100m)	Tension on Cable (N)					
		Span (m)					
		50m	100m	150m	200m	250m	300m
(a)	(b)	(c)	(d)	(e)	(f)	(g)	(h)
1	20	0.68	1.37	2.05	2.74	3.34	4.11
2	30	1.07	2.05	3.03	4.11	5.09	6.07
3	40	1.47	2.74	4.11	5.39	6.86	8.13
4	50	1.76	3.43	5.09	6.86	8.52	10.19
5	60	2.05	4.11	6.17	8.13	10.19	12.15
6	70	2.35	4.7	7.15	9.5	11.85	14.21
7	80	2.74	5.39	8.13	10.78	13.62	16.26
8	90	3.03	6.17	9.21	12.15	15.09	18.32
9	100	3.43	6.86	10.19	13.62	16.95	20.79
10	120	4.11	7.54	12.15	16.26	20.58	24.5
11	140	4.8	8.13	14.21	18.42	23.71	28.42
12	160	5.39	10.78	16.26	21.65	27.04	32.43
13	180	6.17	12.15	18.32	24.5	30.38	36.55
14	200	6.86	13.62	20.58	27.04	33.81	40.57
15	220	6.56	14.89	22.63	29.79	37.24	44.59
16	240	8.13	16.26	24.5	32.43	40.57	48.7

Fig 9-5 Unloaded tension of suspended cables

## ANNEX A

### DESIGN PROFORMA FOR FIELD MACHINES

9A-1. This example considers all of the important aspects common to field machine construction. Each calculation required for the design and the calculation of necessary tackle systems is covered.

9A-2. Proformae are used to ensure that no critical area is overlooked, that all necessary calculations are completed and that the builder is provided with all of the information necessary and all of the stores required to complete the task. Finally, proformae are produced and used to permit the design to be done under less than ideal conditions. Any proforma is acceptable, if it meets these aims.

9A-3. There are constants used in the proforma that have been developed as quick rules of thumb that remove the necessity for lengthy calculations in the design process. An example of these constants is the value 4000 which is the calculation of the weight of the sheer. The following discussion illustrates the development of this and other constants.

The cross sectional area of each spar =  $\pi r^2$  and there are 2 legs to lift. The leg length used to calculate the weight will be the actual length (L act). The planning mass of softwood is 640 kg / m<sup>3</sup>.

Therefore:  $\pi r^2 \times L \text{ act} = \text{volume of one leg}$  and  
 $\pi r^2 \times L \text{ act} \times 2 = \text{volume of both legs.}$   
 $\pi r^2 \times L \text{ act} \times 2 \times 640 = \text{total mass.}$

The equation can be written like this:

$$\text{Total Mass} = r^2 \times L \text{ act} \times 3.14 \times 2 \times 640.$$

With the constants combined the formula looks like this:

$$= r^2 \times L \text{ act} \times 4019.2$$

The degree of accuracy required for this design does not include the 19.2 so 4000 is close enough.

<b>PROFORMA FOR THE DESIGN OF AN ELEVATED CABLE</b>	
<b>NOTES:</b>	
1. Many of the abbreviations that have been used in this proforma have no other application and should not be applied elsewhere. 2. The symbol {} has been used to indicate the location of the required data.	
<b>PART ONE - BASE REQUIREMENT CALCULATIONS</b>	
1. RECCE DATA REQUIRED (water level is datum) <ul style="list-style-type: none"> <li>a. elevation of banks               <ul style="list-style-type: none"> <li>(1) home</li> <li>(2) far</li> </ul> </li> <li>b. AR span</li> <li>c. type of ground               <ul style="list-style-type: none"> <li>(1) home</li> <li>(2) far</li> </ul> </li> <li>d. tail length ratio               <ul style="list-style-type: none"> <li>(1) home</li> <li>(2) far</li> </ul> </li> </ul>	  + 9.8m + 16m 117m  <u>Good &amp; hard</u> <u>Normal</u>  1 : 4 1 : 2
2. KNOWN DATA <ul style="list-style-type: none"> <li>a. largest load to be moved               <ul style="list-style-type: none"> <li>(1) height</li> <li>(2) length</li> <li>(3) mass</li> </ul> </li> <li>b. fibre rope available               <ul style="list-style-type: none"> <li>(1) types</li> <li>(2) sizes</li> <li>(3) blocks</li> </ul> </li> <li>c. SWR available</li> </ul>	  3.5 m 4.2 m 409 kg  <u>Manila &amp; nylon</u> <u>All to 28 mm</u> <u>New</u> <u>1770 ips</u>



3. CABLE ELEVATION DATA

a. diagram

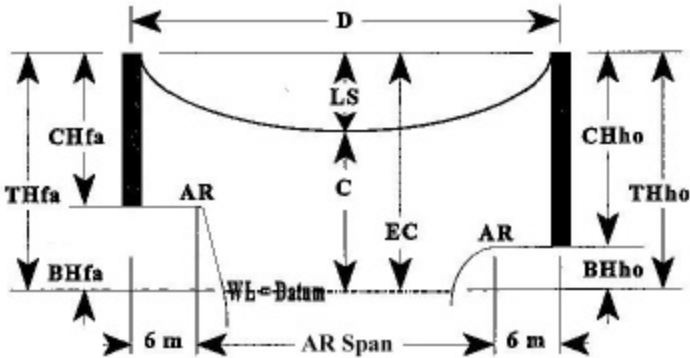

b. definitions:

- |                                 |  |
|---------------------------------|--|
| TH total height                 | C clearances                               |
| BH bank height                  | D distance between supports                |
| CH cable height                 | fa far side                                |
| EC minimum elevation of cable   | LS laden cable sag (5%)                    |
| ho home side                    | MV maximum allowable variation (not shown) |
| AV actual variation (not shown) | RA required adjustment (not shown)         |

Note: 6m on each bank is reserved for construction room.

4. PRIMARY CALCULATIONS

- |   |        |
|---|--------|
| a. $D = AR \text{ Span } \{1b\} + 12m =$    | 129m   |
| b. $LS = D \{4a\} \times 0.05 =$            | 6.25m  |
| c. $C = \text{load height } \{2a1\} + 2m =$ | 5.5m   |
| d. $EC = LS \{4b\} + C \{4c\} =$            | 11.95m |
| e. $CHho = EC \{4d\} - BHho \{1a1\} =$      | 2.15m  |
| f. $CHfa = EC \{4d\} - BHfa \{1a2\} =$      | -4.05m |

5. ADJUSTMENT OF CH VALUES FOR MIN HEIGHT REQUIREMENTS

- |   |                  |
|---|------------------|
| a. both CH values must be = or > the value of C |                  |
| b. $CHho \{4e\} = 2.15m. C \{4c\} = 5.5m.$      | Use CHho of 5.5m |
| c. $CHfa \{4f\} = -4.05m. C \{4c\} = 5.5m.$     | Use CHfa of 5.5m |

6. ADJUSTMENT OF CH VALUES FOR BANK HEIGHT VARIATION TOLERANCES		
a. max variation = $D \{4a\} \times 0.04 MV =$		5.16m
THho = $BHho \{1a1\} + CHho \{5b\} =$		15.3m
c. $THfa = BHfa \{1a2\} + CHfa \{5c\}$		21.5m
d. Actual Variation between $\{6b\}$ and $\{6c\}$ AV =		6.2m
e. Is AV $\{6d\}$ less than MV $\{6a\}$ ?	<del>YES</del>	NO
f. If <b>YES</b> , cables are at correct height and need no further adjustment. Use cable heights at $\{5b\}$ and $\{5c\}$ for final heights in $\{6j\}$ and $\{6h\}$ .		
g. If <b>NO</b> , subtract MV from AV to find required adjustment. $RA = AV \{6d\} - MV \{6a\} = 6.2 - 5.16 =$ Add RA to the CH on the <b>lowest</b> bank home - $CHho \{5b\} + RA = 5.5 + 1.04 =$ far - $CHfa \{5c\} + RA = \_ + \_ = N/A$ Use this value for the final value in $\{6h\}$ or $\{6j\}$ For other bank, use CH value from $\{5b\}$ or $\{5c\}$		1.04m 6.54m
h. Final cable height home bank value will be Chho =		6.54m
j. Final cable height far bank value will be CHfa =		5.5m
7. MAIN CABLE SELECTION DATA		
a. diagram		
<p>The diagram shows two towers of heights <math>H_{fa}</math> and <math>H_{ho}</math> separated by a distance <math>D</math>. The cable is anchored to the ground at distances <math>S_{fa}</math> and <math>S_{ho}</math> from the towers. The cable heights at the towers are <math>CH_{fa}</math> and <math>CH_{ho}</math>. The slopes are given as <math>1:2</math> for the far side and <math>1:4</math> for the home side.</p>		
b. more definitions		
H = length of hypotenuse of triangle formed by tower and anchor		
S = amount of cable allowed to secure the cable to the anchor		
c. ratio of H to CH values at known slopes		
1:1 = 1.414    1:2 = 2.244    1:3 = 3.147    1:4 = 4.14		
FAR		HOME

<p>8. MAIN CABLE LENGTH CALCULATIONS</p> <p>a. <math>H_{fa} = CH_{fa} \{6j\} \times \{7c\} = 5.5 \times 2.244 =</math></p> <p>b. <math>H_{ho} = CH_{ho} \{6h\} \times \{7c\} = 6.54 \times 4.14 =</math></p> <p>c. <math>S_{fa} + S_{ho}</math>, at 1.25m each, <math>= 2 \times 1.25 =</math></p> <p>d. main cable length  <math>= (D\{4a\} + H_{fa}\{8a\} + H_{ho}\{8b\} + S\{8c\}) \times 1.25</math>  <math>= (129 + 12.34 + 27.07 + 2.25) \times 1.25 =</math></p>	<p>12.342m</p> <p>27.075m</p> <p>2.5m</p> <p>213.63m</p>
<p>9. DETERMINE CABLE TYPE REQUIRED</p> <p>a. load mass <math>= \{2a3\} \times 1.25 = 409 \times 1.25 =</math></p> <p>b. mass of traveller (planning constant, change if necessary) <math>=</math></p> <p>c. total mass <math>= (\{9a\} + \{9b\}) \times 1.1 = (511.25 + 50) \times 1.1 =</math></p> <p>d. select cable from tables <b>{Fig 9-4}</b></p> <p>(1) diameter <math>=</math></p> <p>(2) tension under load <math>=</math></p>	<p>511.25kg</p> <p>50kg</p> <p>617.37kg</p> <p>24mm</p> <p>46kN</p>
<p>10. DESIGN SPAR LENGTH REQUIREMENTS FOR FIELD MACHINES</p> <p>a. leg length home side</p> <p>(1) machine will be gyn or sheer</p> <p>(2) effective length <math>= (Ch_{ho}\{6h\} + 1m) \times 1.03</math>  <math>= (6.54 + 1) \times 1.03 =</math></p> <p>(3) Lact <math>=</math> effective length <math>+ 0.8m</math>  <math>= 7.76 + 0.8 =</math></p> <p>b. leg length far side</p> <p>(1) machine will be gyn or sheer</p> <p>(2) effective length <math>= (Ch_{fa}\{6j\} + 1m) \times 1.03</math>  <math>= (5.5 + 1) \times 1.03 =</math></p> <p>(3) Lact <math>=</math> effective length <math>+ 0.8m</math>  <math>= 6.69 + 0.8 =</math></p>	<p><u>Sheer</u></p> <p>7.76m</p> <p>8.56m</p> <p><u>Gyn</u></p> <p>6.69 m</p> <p>7.49 m</p>
<p><b>PART TWO - HOME SIDE CALCULATIONS</b></p>	
<p>11. MACHINE USED. If Gyn used, delete paragraphs 15 to 21 inclusive and 41. If Sheer used, delete paragraphs 12 to 14 inclusive.</p>	<p><u>Sheer</u></p>
<p>12. GYN TIMBER HOME SIDE</p> <p>a. diameter of gyn legs</p> <p>(1) load <math>=</math> loaded tension <math>\{9d2\} \times 0.6 =</math>          {if no leading block on gyn, use 0.4 vice 0.6}</p> <p>(2) diameter (using effective length found in <b>{10a2}</b>)</p> <p>b. diameter of gyn ledgers  <math>=</math> dia of gyn legs <math>\{23a2\} \times 0.5 =</math></p> <p>c. length of gyn ledgers <math>= (\{10b2\} \times 0.5) + .6 =</math></p>	<p><u>N/A</u></p>

<p>13. GYN LASHING HOME SIDE</p> <p>a. calculate length of gyn spar lashing  <math>100 \times \text{leg dia. (m)} \{23a2\} =</math></p> <p>b. calculate length of gyn ledger lashing  <math>= \text{leg dia } \{23a2\} \div 25 \times 2 =</math>  (Remember there are three ledgers!)</p> <p>c. calculate diameter of all gyn lashings,  <math>= \text{gyn leg dia (mm)} \{23a2\} \times 0.08 \text{ (minimum 16mm)} =</math></p>	<u>N/A</u>
<p>14. CALCULATE LEADING BLOCK LASHING FOR HOME SIDE GYN</p> <p>a. diameter same as other lashings for convenience =</p> <p>b. length = gyn leg dia(m) <math>\{12a2\} \times 30 =</math></p>	<u>N/A</u>
<p>15. SHEER TIMBER HOME SIDE</p> <p>a. diameter of sheer legs home side</p> <p>(1) load = loaded tension <math>\{9d2\} \times 1.2 = 46 \times 1.2 =</math>  (if no leading block on sheer, then <math>\times 1</math> vice 1.2)</p> <p>(2) diameter (table <math>\{\text{Fig 8-2-3}\}</math>) (using effective length found in <math>\{10a2\}</math>)</p> <p>b. diameter of sheer ledger = sheer leg dia. <math>\{15a2\} \times 0.05</math>  <math>= 275 \times 0.5 =</math></p> <p>c. length of sheer ledger = <math>\{10a2\} \times 0.5 + 0.6</math>  <math>= 7.76 \times 0.5 + 0.6 =</math></p>	<p style="text-align: right;">55.2kN</p> <p style="text-align: right;">75 mm</p> <p style="text-align: right;">138mm</p> <p style="text-align: right;">4.49m</p>
<p>16. SHEER LASHINGS HOME SIDE</p> <p>a. calculate length of sheer spar lashings (m):  <math>= 100 \times \text{leg dia. (mm)} \{15a2\} = 100 \times 275 =</math></p> <p>b. calculate length of sheer ledger lashings (m):  <math>= (\text{leg dia. (mm)} \{15a2\} \div 25) \times 2</math>  <math>= (275 \div 25) \times 2 =</math></p> <p><b>Error! Unknown switch argument..</b> calculate diameter of all sheer lashings  <math>= \text{leg diameter (mm)} \{15a2\} \times 0.08</math>  <math>= 275 \times 0.08 = \text{(minimum 16 mm)}</math></p>	<p style="text-align: right;">27.5m</p> <p style="text-align: right;">22m</p> <p style="text-align: right;">22mm</p>
<p>17. CALCULATE REQUIREMENTS - LEADING BLOCK - SHEER - HOME SIDE</p> <p>a. diameter same as other lashings for convenience =</p> <p>b. length = sheer leg dia (mm) <math>\{15a2\} \times 30 =</math></p>	<p style="text-align: right;">22mm</p> <p style="text-align: right;">8.25m</p>

<p>18. CALCULATE MINIMUM LENGTH OF BACK-STAY (AND FORESTAY) FOR SHEER</p> <p>a. at 1:2 ratio (eff length {10a2} x 2.574) + (12.5 x leg dia.(m){15a2}) + 1</p> <p>b. at 1:3 ratio (eff length {10a2} x 3.504) + (12.5 x leg dia.(m){15a2}) + 1</p> <p>c. at 1:4 ratio (eff length {10a2} x 4.47) + (12.5 x leg dia.(m){15a2}) + 1</p> <p>d. (7.76 x 4.47) + (12.5 x 0.275) + 1 =</p>	<p>39.1m</p>
<p>19. CALCULATE DIAMETER OF BACKSTAY CABLE</p> <p>a. load on backstay = 70% of total load(kg) {9d2} = 0.7 x 46000 =</p> <p>b. select rope to be used (minimum 16mm)(from table at {Fig 2-6-3})</p> <p>(1) dia</p> <p>(2) type</p>	<p>32,200N</p> <p>22mm</p> <p><u>Manila</u></p>
<p>20. DETERMINE SIZE OF CABLE REQUIRED FOR SHEER LIFTING TACKLE</p> <p>a. block to be used</p> <p>(1) type of tackle</p> <p>(2) theoretical gain (G)</p> <p>(3) number of sheaves (n)</p> <p>b. condition of blocks {2b3} (f)</p> <p>c. mass to be moved = r<sup>2</sup> (m) {15a2} x Lact {10a3} x 4000 = 0.137 x 0.137 x 8.56 x 4000 =</p> <p>d. tension on the cable = (W{20c} ÷ G{20a2}) x (1+ (f{20b} n {20a3})) x 9.8 = (642.65 ÷ 7) x ( 1+( 0.1 x 6) ) x 9.8 =</p> <p>e. SWL used to select cable = tension {20d} x safety factor of 7 = 1440 x 7 =</p> <p>f. select cable (minimum required 16mm) (from table at {Fig 2-6-3})</p> <p>(1) rope diameter =</p> <p>(2) type</p>	<p><u>3/3</u></p> <p><u>running</u></p> <p><u>7</u></p> <p><u>6</u></p> <p><u>0.1</u></p> <p>642.65kg</p> <p>1440N</p> <p>10,080N</p> <p><u>16 mm</u></p> <p><u>Manila</u></p>

<p>21. DETERMINE LENGTH OF ROPE REQUIRED FOR SHEER LIFTING TACKLE</p> <p>a. distance between blocks: effective length <math>\{10a2\}+2m = 7.76+2 =</math></p> <p>b. number of returns <math>\{20a2\} - 1 = 7 - 1 =</math></p> <p>c. length required for personnel to pull <math>= \text{tension } \{20d\} \div 27 = 147.96 \div 27 = 5.4</math>, rounded to</p> <p>d. total rope required <math>= (\{21a\} \times \{21b\} \times 1.25) + \{21c\}</math> <math>= (9.76 \times 6 \times 1.25) + 6 = 79.2</math> rounded to</p>	<p>9.76m</p> <p>6</p> <p>6m</p> <p>80m</p>
<b>PART THREE - FAR SIDE CALCULATIONS</b>	
<p>22. MACHINE USED. If gyn used, delete paragraphs 26 to 32 inclusive and 42. If sheer used, delete paragraphs 23 to 25 inclusive.</p>	<u>GYN</u>
<p>23. FAR SIDE GYN TIMBER</p> <p>a. diameter of gyn legs</p> <p>(1) load = loaded tension <math>\{9d2\} \times 0.6 = 46 \times 0.6 =</math> (if no leading block on gyn, use 0.4 vice 0.6)</p> <p>(2) diameter {table at <b>Fig 8-2-3</b>} (using effective length found in <b>{10b2}</b> )</p> <p>b. diameter of gyn ledgers = dia of gyn legs <math>\{23a2\} \times 0.5</math> <math>= 200 \times 0.5 =</math></p> <p>c. length of gyn ledgers = <math>(\{10b2\} \times 0.5) + 0.6</math> <math>= (6.69 \times 0.5) + 0.6 =</math></p>	<p>27.6kN</p> <p>200mm</p> <p>100mm</p> <p>3.945m</p>
<p>24. FAR SIDE GYN LASHING</p> <p>a. calculate length of gyn spar lashing <math>= 100 \times \text{leg dia(m)} \{23a2\} = 100 \times 0.2 =</math></p> <p>b. calculate length of gyn ledger lashing <math>= \text{leg dia} \{23a2\} \div 25 \times 2 = 200 \div 25 \times 2 =</math> (Remember there are three ledgers)</p> <p>c. calculate diameter of all gyn lashings <math>= \text{gyn leg dia (mm)} \{23a2\} \times 0.08</math> <math>= 200 \times 0.08</math> (minimum 16mm) =</p>	<p>20m</p> <p>16m</p> <p>16mm</p>
<p>25. CALCULATE LEADING BLOCK LASHING FOR FAR SIDE GYN</p> <p>a. diameter same as other lashings for convenience =</p> <p>b. length = gyn leg dia.(m) <math>\{12a2\} \times 30 =</math></p>	<u>N/A</u>

<p>26. FAR SIDE SHEER TIMBER</p> <p>a. diameter of sheer legs            (1) load = loaded tension <b>{9d2}</b> x 1.2 =            (if no leading block on sheer, then x 1.0 vice 1.2)            (2) diameter (table at <b>{Fig 8-2-3}</b>) (using effective length found in <b>{10b2}</b>)</p> <p>b. diameter of sheer ledgers dia.            = sheer leg dia. <b>{26a2}</b> x 0.5 =</p> <p>c. length of sheer ledgers = <b>{10b2}</b> x 0.5 + 0.6 =</p>	<u>N/A</u>
<p>27. FAR SIDE SHEER LASHINGS</p> <p>a. calculate length of sheer spar lashing            = 100 x leg dia.(m) <b>{26a2}</b> =</p> <p>b. calculate length of sheer ledger lashing            = leg dia.(m) <b>{26a2}</b> ÷ 25 x 2 =</p> <p>c. calculate diameter of all sheer lashings,            = gyn leg dia (mm) <b>{26a2}</b> x 0.08 (minimum 16mm) =</p>	<u>N/A</u>
<p>28. CALCULATE REQUIREMENTS FOR FAR SIDE SHEER LEADING BLOCK</p> <p>a. diameter same as other lashings, for convenience =</p> <p>b. length = sheer leg dia.(m) <b>{26a2}</b> x 30 =</p>	<u>N/A</u>
<p>29. CALCULATE MINIMUM LENGTH OF BACKSTAY {AND FORESTAY} FOR SHEER</p> <p>a. at 1:2 ratio (eff length <b>{10b2}</b> x 2.574) +            (12.5 x leg dia.(m)<b>{26a2}</b>) + 1</p> <p>b. at 1:3 ratio (eff length <b>{10b2}</b> x 3.504) +            (12.5 x leg dia.(m)<b>{26a2}</b>) + 1</p> <p>c. at 1:4 ratio (eff length <b>{10b2}</b> x 4.47) +            (12.5 x leg dia.(m)<b>{26a2}</b>) + 1</p>	<u>N/A</u>
<p>30. CALCULATE DIAMETER OF BACKSTAY CABLE</p> <p>a. load on backstay = 70% of total load(kg) <b>{9d2}</b> =</p> <p>b. select rope to be used (minimum 16mm) (from table at <b>{Fig 2-6-3}</b>)</p> <p>(1) dia</p> <p>(2) type</p>	<u>N/A</u>

<p>31. DETERMINE SIZE OF CABLE REQUIRED FOR SHEER LIFTING TACKLE</p> <p>a. block to be used  (1) type of tackle  (2) theoretical gain (G)  (3) number of sheaves (n)</p> <p>b. condition of blocks {2b3} (f)</p> <p>c. weight to be moved  = <math>r^2</math> (m) {26a2} x Lact {10b3} x 4000 =</p> <p>d. tension on the cable  = <math>(W\{31c\} \div G\{31a2\}) \times (1 + (f\{31b\}n\{31a3\})) =</math></p> <p>e. SWL used to select cable  = tension {31d} x safety factor of 7</p> <p>f. select cable (min 16mm){Fig 2-6-3}  (1) rope diameter  (2) type</p>	<u>N/A</u>
<p>32. DETERMINE LENGTH OF ROPE REQUIRED FOR SHEER LIFTING TACKLE</p> <p>a. distance between blocks eff length = {10a2} + 2m =</p> <p>b. number of returns {20a2} - 1 =</p> <p>c. length required for personnel to pull = tension {20d} <math>\div</math> 27 =</p> <p>d. total rope required = <math>(\{32a\} \times \{32b\} \times 1.25) + \{32c\} =</math></p>	<u>N/A</u>
<b>PART FOUR – DESIGN COMMON SYSTEMS</b>	
<p>33. DESIGN TRAVELLER TACKLE</p> <p>a. weight = heaviest load {2a3} =</p> <p>b. use 3/3 lifting tackle  (1) theoretical gain (G)  (2) number of sheaves (n)</p> <p>c. condition of blocks {2b3}  (new 0.1, fair 0.15, old 0.2) (f)</p> <p>d. tension on cable:  = <math>(W\{33a\} \div G\{33b1\}) \times (1 + (f\{33c\}n\{33b2\})) \times 9.8 =</math>  = <math>(409 \div 6) \times (1 + (0.1 \times 6)) \times 9.8 =</math></p> <p>e. SWL used to select cable  = tension {33d} x safety factor of 7 = <math>1069.8 \times 7 =</math></p> <p>f. select cable (min 16mm) {Fig 2-6-3}  (1) rope diameter = 12; so use  (2) type</p>	<p>409 kg</p> <p>6</p> <p>6</p> <p>0.1</p> <p>1,069.8N</p> <p>7,488N</p> <p>16mm</p> <p><u>Manila</u></p>



<p>34. DETERMINE LENGTH OF ROPE REQUIRED FOR TRAVELLER TACKLE</p> <p>a. length required for pullers = the greater of {6h} or {6j} = 6.54 or 5.5; use</p> <p>b. distance between blocks = the greater of {6h} or {6j} -(load height {2a1} + 1) = 6.54 - (3.5 + 1) = 6.54 - 4.5 =</p> <p>c. number of returns =</p> <p>d. total rope required = ({34b} x {34c} x 1.25) + {34a} = (2.04 x 6 x 1.25) + 7 =</p>	<p>6.54m</p> <p>2.04m</p> <p>6</p> <p>22.3m</p>
<p>35. DESIGN SPREADER AND SPREADER LASHINGS</p> <p>a. spreader diameter = 70mm minimum. Use</p> <p>b. spreader length = load length {2a2}+0.6m = 4.2 +.6 =</p> <p>c. lashing lengths =spreader dia.(mm) {35a} ÷ 25 x 2 = 70 ÷ 25 x 2 =</p> <p>d. lashing diameter same as {33f1} for convenience =</p>	<p>70m</p> <p>4.8m</p> <p>5.6m</p> <p>16mm</p>
<p>36. CALCULATE REQUIREMENTS FOR LOAD HAULING ROPES</p> <p>a. length of each rope =D{4a} =</p> <p>b. minimum dia for rope handled by personnel = 16mm so use</p>	<p>129m</p> <p>16mm</p> <p><u>Manila</u></p>
<p>37. SELECT CABLE FOR TACKLE USED TO TENSION MAIN CABLE</p> <p>a. mass per 100m of main cable = (from table at {Fig 3-4-2}) {9d1}</p> <p>b. unloaded main cable tension = (from table at {Fig 9-5}) x 1000 =</p> <p>c. use 3/3 running (from table at {Fig 7-3-3}) (1) theoretical gain = (G) <u>7</u> (2) number of sheaves = (n) <u>6</u></p> <p>d. condition of blocks = {2b3} (new 0.1; fair 0.15; old 0.2) (f) <u>0.1</u></p> <p>e. tension on cable = (W{37b} ÷ G{37c1}) x (1 + (f{37d} n {37c2})) = (24,500 ÷ 7) x (1 + (0.1 x 6))=</p> <p>f. SWL (cable selection) = tension x safety factor = 5600 x 7 =</p> <p>g. select cable (Table at {Fig 2-6-3}) (1) diameter = 16mm (2) type = <u>Nylon</u></p>	<p>253kg</p> <p>24,500N</p> <p><u>7</u></p> <p><u>6</u></p> <p><u>0.1</u></p> <p>5,600N</p> <p>39,200N</p> <p>16mm</p> <p><u>Nylon</u></p>

<p>38. DETERMINE LENGTH OF ROPE REQUIRED FOR MAIN CABLE TENSIONING</p> <p>a. distance between blocks normally 7m. Use</p> <p>b. number of returns</p> <p>c. length required for personnel to pull  = weight per 100m {37a} x main cable length {8d} ÷ 2700  = 253 x 213.64 ÷ 2700 =</p> <p>d. total rope required  = ({38a} x {38b} x 1.25) + {38c}  = (7 x 6 x 1.25) + 20 =</p>	<p>7m</p> <p>6</p> <p>20.018m</p> <p>72.5m</p>
<p>39. ANCHOR SELECTION DATA (refer to text) {Fig 6-1-25}</p>	
<p>40. SELECT ANCHORS FOR MAIN CABLE</p> <p>a. pull on anchor  = loaded tension {9d2}+10%  = 46,000 x 1.1 =</p> <p>b. home ground {1c1}  Select OPH type or design a buried ancrage</p> <p>c. far ground {1c2}.  Select OPH type or design deadman</p>	<p>50,600N</p> <p><u>Good</u></p> <p><u>Three Spread</u></p> <p><u>Average</u></p> <p><u>Three Spread</u></p>
<p><b>PART FIVE - SELECT ANCHORS FOR SHEERS</b></p>	
<p>41. HOME SIDE ANCHOR FOR SHEER FORE AND BACKSTAY</p> <p>a. pull on anchor = load on backstay {19a} =</p> <p>b. select OPH type or design a buried anchor</p>	<p>32,200N</p> <p><u>Two in line</u></p> <p># ____</p>
<p>42. FAR SIDE ANCHOR FOR SHEER FORE AND BACKSTAY</p> <p>a. pull on anchor = load on backstay {30a} =</p> <p>b. select OPH type or design a buried anchor</p>	<p><u>N/A</u></p> <p># _____</p>
<p>43. DISPOSITION OF MAIN CABLE ANCHRAGES.</p> <p>a. distance home side cable will be anchored behind centre of support  =CHho{6j} x ratio {1d1} =6.54 x 4 =</p> <p>b. distance far side cable will be anchored behind centre of support  =CHfa {6j} x ratio {1d2} = 5.5 x 2 =</p>	<p>26.16m</p> <p>11m</p>

Fig 9A-1 Design proforma for field machines